

ALTHOUGH the original Minisonic was designed with an eye on the younger generations of amateur constructors, it soon became fairly obvious that the instrument was capable of a far wider range of application than was ever initially envisaged. Thus, with the co-operation of a group of musicians, it was decided to submit the original Minisonic to a process of intensive sophistication and re-development, where necessary, in order to see whether it could be turned into a professional quality instrument. The result is an electronic music synthesiser which it is believed will stand direct comparison with commercially available instruments costing upwards of £1,000. Such a result could not have been achieved without the co-operation of Synthesiser Music Services Ltd., to whom the author offers his grateful thanks.

INSTRUMENT DESCRIPTION

The Minisonic II is a three octave keyboard synthesiser featuring push-button patching of audio signal and control voltage options. Two temperature compensated log law v.c.o.s of greatly improved design offer, in addition, facilities for cross modulation and phase locking up to the ninth harmonic. These latter features considerably extend the range of sounds of which the instrument is capable and it is particularly easy to create close imitations of a number of reed or woodwind instruments.

Two envelope shapers and voltage controlled amplifiers are incorporated with the envelope from channel 1, being made available in its normal and inverted form as a modulation source. The envelope state from each device is monitored by a light emitting diode which varies in brightness with the envelope level.

The keyboard controller is similar in form to that which appeared in the original Minisonic but offers a number of improvements. Like the original it is possible to adjust the register and span of the keyboard but, in the case of the Minisonic II, provision has been made for balancing the gain of the operational amplifiers in the controller so that interaction between tune and span controls can be eliminated. Additionally, an equal temperament span is available at the touch of a button. The hold circuit, or pitch memory, of the controller has been provided with a variable "Portamento" control so that glide effects of up to one second duration may be achieved.

In addition an isolator has been incorporated to reduce drain on the hold capacitor thereby ensuring that an unvarying pitch may be maintained for periods up to 40 seconds.

A voltage controlled low-pass filter having a passband variable in the range 3Hz-15kHz is incorporated.

RING MODULATOR

Another sound treatment device is the ring modulator which may be used as a frequency doubler or multiplier giving sum and difference frequencies each with a gain of about 25dB. Provision is made to route external signals into the ring modulator.

The noise generator is essentially the same

circuit which appeared in the original Minisonic except that it now features an up-to-date version of the Z1J, appearing in axial form as the Z5J noise diode.

The output stages comprise, in each stage, a two input summing mixer and a 0.25 watt power amplifier which is arranged for headphone driving. A headphone jack is provided for this purpose although the output from this jack socket may also be directly linked to a pair of 8 ohm external speakers if required. The output from each mixer stage is routed to separate jack sockets on the rear panel of the instrument. Drive to the output stages is taken from the voltage controlled amplifiers via panning controls so that there is provision for a subjective spatial positioning of the signal elements in a stereo image.

KEYBOARD AND SWITCHES

The keyboard and contact assemblies are of the type supplied by Kimber Allen Ltd. The keyboard frame, which is an exceptionally rigid aluminium extrusion, forms a bridge between two end cheeks manufactured from solid afrormosia/teak. Additional stiffening and rigidity are provided by the front and base panels which are of 14 s.w.g. aluminium and screwed to aluminium angles in turn screwed into the end cheeks. The flat rear panel carries the circuit boards of the synthesiser and is hinged to the top edge of the front panel. Thus the whole of the electronics of the instrument are easily available for servicing and/or setting up.

Constructors who have built the original Minisonic may be interested to learn that although a number of design changes have taken place it should be possible to convert existing instruments to the improved form with a minimum of difficulty.

COMPONENT NUMBERING

For the Minisonic II component numbering will follow a logical sequence. Where there are two circuits of one type the components will be numbered, for example, R23/1 or R23/2 and so on. For the benefit of those constructors wishing to convert an original Minisonic, the alphabetical coding for circuit board pins has been retained but, since there are a number of extra pins required, these will be given the same coding as the nearest adjacent pin followed by the suffix /X, i.e. P/X, JJ/X and so on.

Apart from the push button patching system which embodies a series of additional components, a number of additional active and passive electronic components are required. These components, together with other component value changes, will be itemised at the beginning of each section again for the benefit of original Minisonic constructors.

It is strongly recommended that construction should follow a pattern in which individual circuits are built and tested as separate units. Experienced constructors should not find much difficulty if they press on ahead and save all the setting-up to one marathon end-of-project session. However, the not so experienced constructor would be well advised to heed this recommendation and thereby save a great many possible problems.

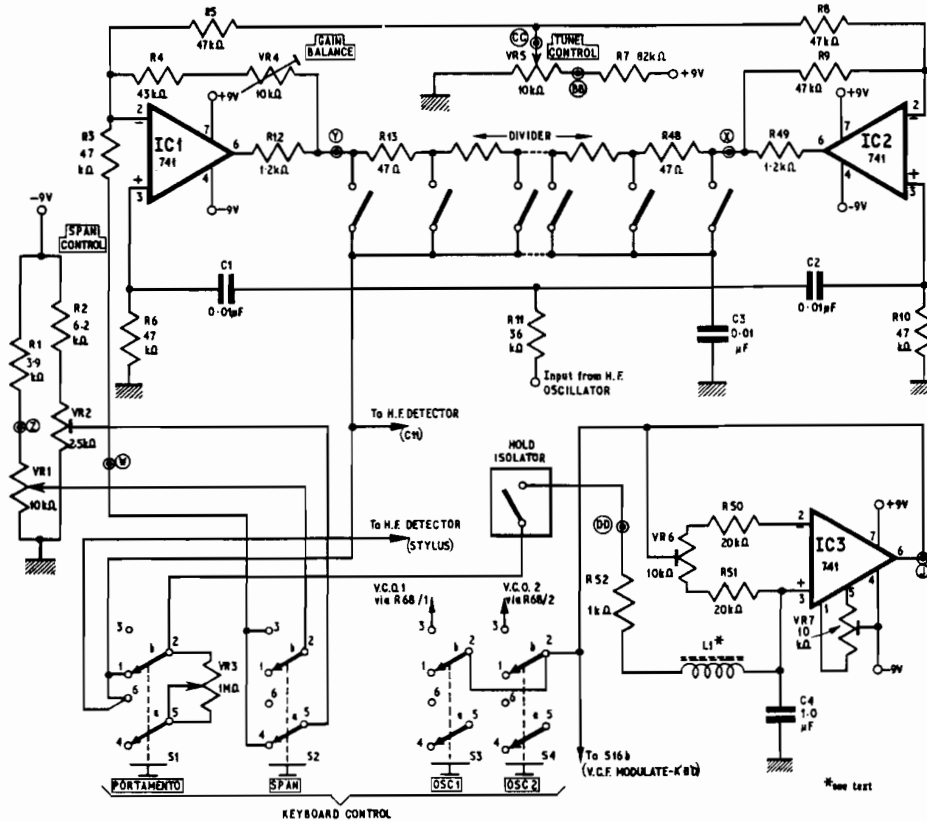

Fig. 1. The keyboard controller and hold circuit

Testing of individual circuits is, of course, rather time consuming since it frequently requires components external to the circuit board to be connected temporarily. It is well worth doing though and a great morale booster when, as construction proceeds, it is known that all one's previous work is functioning correctly. It is quite in order to employ batteries to power the circuit boards for testing. PP9s are an ideal size and should see through all the testing procedures quite adequately.

It is a good idea to obtain some fairly substantial reservoir capacitors of, say, 1,000 μ F, for connecting across the batteries particularly as the circuit board begins to fill up. This will help to prevail against the increasing resistance or "stiffness" of the battery as voltage tends to fall with the increased drain.

TEST EQUIPMENT

Most of the routine testing and setting up may be accomplished with a good quality high resistance voltmeter. Whilst such meters are perfectly suitable for measuring fairly high level voltages and, in many instances currents down to a few microamps, it should be borne in mind that where low level voltages are being measured in the presence of a substantial resistance value, there is a danger that the meter can load the circuit thereby introducing an error into the reading.

COMPONENTS . . .

KEYBOARD CONTROLLER AND HOLD

Resistors

R1	3.9k Ω	R8-10	47k Ω (3 off)
R2	6.2k Ω	R11	36k Ω
R3	47k Ω	R12	1.2k Ω
R4	43k Ω	R13-48	47 Ω (36 off)
R5-6	47k Ω (2 off)	R49	1.2k Ω
R7	82k Ω	R50-51	20k Ω
All	$\pm 5\%$ $\frac{1}{4}$ W carbon	R52	1k Ω

Capacitors

C1-3	0.01 μ F ceramic (3 off)
C4	1 μ F metal polyester

Integrated Circuit

IC1-3 741 (3 off) or 741 (2 off) FETMOPA (1 off)

Inductor

L1 100 turn of 34 s.w.g. on ring core CRO71-12A/A (ITT)

Potentiometers

VR1	10k Ω linear
VR2	2.5k Ω preset
VR3	1M Ω linear
VR4	10k Ω preset
VR5	10k Ω linear, 10 turn wire wound
VR6	10k Ω preset 20 turn
VR7	10k Ω preset 20 turn

It is recommended that where low levels are to be measured a d.c. coupled oscilloscope or active voltmeter having an input resistance of at least 1 megohm should be used. The oscilloscope is, of course, an excellent test instrument particularly if it is d.c. coupled and those constructors having access to one will find that testing and setting up is greatly simplified.

What follows now is a detailed description of circuit function.

KEYBOARD CONTROLLER

The keyboard controller as illustrated in Fig. 1 is a means of providing a range of control voltages which, when applied to the input of a voltage controlled oscillator, cause it to oscillate over a range of pitches normally associated with the equal temperament chromatic scale or, alternatively, over a range of pitches quite outside what might be termed normal musical acceptance.

Components additional to those in the basic Minisonic are as follows: R2, VR2, VR3, R4, VR4, R6, R10, R11, R12, R49, R52, C1, C2, C3. The hold isolator is an additional active circuit entity and will be dealt with in a following section.

IC1 and IC2 are inverting operational amplifiers whose outputs are linked by a chain of resistors, the junctions between which are connected to the keyboard contacts. R7 and VR5 form a voltage divider between the positive rail and ground such that the swing of the potentiometer covers a range of about 4.7 volts. The wiper of VR5 is linked to both i.c.s so that the outputs of these devices will track, in unison, the setting of VR5. R1 and VR1 form a second voltage divider connected between the negative rail and ground with the wiper linked to IC1 only. Thus VR1 is able to provide an offset to IC1 which is variable over 4.5 volts.

TUNE AND SPAN

The purpose of VR5, the "Tune" control, is to set the upper frequency limit of the three octave keyboard. With a control voltage law of 500mV/octave VR1, the "Span" control, is adjusted to provide an offset of 1.5V to IC1. Since the divider resistors R13-R48 are of equal value, equal voltage increments will appear across each resistor and the "logarithmic" oscillator will be programmed to produce an equal temperament scale. If it is assumed that the setting of the "Span" control is now fixed then VR5 may be adjusted over a wide range without varying the equal temperament capability of the oscillators.

This only holds good, of course, if the gains of IC1 and IC2 are identical. If there is any variation in gain then any change in the setting of VR5 will change the span of the keyboard and cause the oscillators to go out of tune. The arrangement of R4 and VR4 is introduced, therefore, to enable a close matching between the gains of IC1 and IC2. Ideally, VR4 should be a 15 or 20 turn cermet preset.

The purpose of R2 and VR2 is to provide a preset or fixed span facility which may be alternated with the

variable span by means of S2a/b. This facility offers the advantage for "live" performance that the variable span position may be adjusted to provide a microtone or macrotone span between consecutive notes and then switched in as required to provide a particular effect.

DIVIDER RESISTORS

The values of the divider resistors R13-R48 are not critical although they should ideally be around 47Ω to 56Ω. It is important, however, that whatever value of divider resistor is selected, the total value of resistance per octave is, as far as possible, identical. Unless very high precision resistors are chosen for the divider (a needless expense) then it pays to check each resistor individually, since there will always be slight variation in the ohmic value within the tolerance range of the devices.

If it is found, for example, that there are three resistors which are, say, 1 ohm below the rated value, then these should be allocated the same relative position in each of the three octaves. This means that, providing the same procedure is followed for all other resistor positions, perfect octaves will sound when the span control has been correctly set. Although there may be very slight frequency errors between consecutive notes, these tend, in practice, to be very difficult to detect.

The Minisonic II has a unique method of envelope shaper triggering which enables single contact operation from the keyboard. Detailed operation of the system will be described later but, in brief, it necessitates the superimposition of a very high frequency signal of low amplitude onto the divider resistor chain.

R6, R10, R11, C1 and C2 are additional components which serve to route the high frequency signal into the keyboard controller without it being affected by operation of the "Tune" and "Span" controls.

THE HOLD OR ANALOGUE MEMORY

The sustain function in any musical instrument is of considerable importance in that it imparts a flowing characteristic to the music. In the keyboard controller the closure of a contact instantly programs the oscillator to its specified pitch or frequency and just as instantly removes the programming voltage when the contact is broken. Without some means of sustaining the programming voltage, the resultant "music" would be a series of tone bursts with any sustained tones remaining at a constant loudness only so long as the key contacts are closed.

The hold circuit provides the means whereby the last programmed keyboard voltage is retained, thereby maintaining the oscillators at a constant pitch, either until a new voltage is programmed in or until such time as the envelope shaper has completed its decay cycle.

The hold circuit comprises the components around IC3, an operational amplifier in which the output signal is divided by means of R50, VR6 and R51 in order to provide balanced levels of positive and negative feedback. When the balancing is carefully done

the circuit is theoretically capable of providing an infinite impedance to incoming signals. In practice, however, it is more usual to calculate the input impedance on the basis of the parallel value of the feedback resistors times the open loop gain of the amplifier. Thus, in the circuit under consideration, the input impedance is of the order of 2,500 megohms.

The hold capacitor C4 is ideally a low leakage type. A charge applied to C4 is reflected at the output of IC3 with any drift at the output due to a combination of capacitor leakage and minor thermal effects within the i.c.

BALANCING THE CIRCUIT

It is possible to balance the circuit such that the output drift is better than 1mV/second but to do so requires considerable patience and care. There are at least two methods of balancing the circuit. In the original Minisonic the wiper of VR6 was temporarily disconnected from the output of IC3 and linked to ground with VR6 having first been adjusted so that its wiper was in the electrical centre. A 10 megohm resistor was then temporarily linked between the output and pin 2 of IC3 thereby turning IC3 into a high gain amplifier.

With power applied VR7 was then adjusted so that the output of IC3 was maintained at precisely zero volts. Having thus set the offset of IC3 the circuit was then returned to the form shown in Fig. 1 and the final balancing carried out on completion of the instrument using subjective aural assessment rather than test instruments.

Although the latter method of balancing proved to be very successful it was also rather cumbersome and involved too many manipulations around the circuit. Another method is to carry out the balancing with the circuit as it stands. In this case both VR6 and VR7 require to be set to their electrical centre and a voltmeter, set to the 25V range, coupled between the output of IC3 and ground. With power applied the output of IC3 will tend to drift fairly rapidly either positive or negative depending on the polarity of the offset.

A short piece of wire temporarily connected to the input pin "DD" is then touched on the 0V rail thereby restoring zero output to IC3 and VR7 adjusted, touching the 0V rail as necessary and readjusting, until the output drift has been substantially reduced in rate. At this point the voltmeter can be switched down to a lower range and the exercise repeated until such time as the minimum rate of drift has been achieved by adjustment of VR7. Final adjustment and balancing is then carried out as previously by means of VR6 and aural assessment.

HOLD ISOLATION

Isolation of the front end of the hold circuit is achieved by two means. Firstly, a degree of a.c. isolation is maintained by means of R52 and the high frequency choke, L1. Originally R52 was specified as 20 kilohm with the alternative of replacing this with a ferrite ring carrying approximately 30 turns of 34 s.w.g. enamelled copper wire. On its own the 20

kilohm resistor proved to induce an unacceptable degree of glide when oscillator frequencies were changed by means of the keyboard and, in the prototype Mark II, 30 turns of enamelled copper wire proved to be insufficient to entirely isolate the r.m.s. component of the a.c. signal applied to the divider.

This latter effect is characterised by a slight fall in oscillator pitch each time a key is released. Although this is generally discernible only when any degree of decay is employed it is nevertheless an undesirable characteristic.

Improved a.c. isolation can be achieved by utilising a ring-core type CRO71-12A/A from ITT which carries 100 turns of 34 s.w.g. wire. Additionally a series resistor of the lowest possible value may be added to entirely eliminate the pitch change effect. 1 kilohm has proved, in practice, to be an effective value but introduces a 1 millisecond time constant into the charging rate of the hold capacitor. It is therefore recommended that the value of R52 should not exceed 3 kilohm otherwise the beginnings of a glide effect will become apparent.

REED RELAY

A second means of isolation to the hold circuit is achieved by means of a reed relay introduced between the input of the hold and the "Portamento" controls. The necessity for this feature in the Mark II is based on the fact that the greater length of hold input lead required due to the expanded layout of the instrument introduced a loading effect on the hold capacitor which greatly accelerated the rate of drift. This effect occurred whether or not the input lead was included in, or separate from, the wiring harness of the instrument.

The hold isolator is triggered from the h.f. detector and, since this latter circuit is dependent for its operation on connection to the envelope shapers, details of circuit function will be described in detail in the appropriate section.

PORTAMENTO

In the Mark II a "Portamento" control has been included in the scheme in order to provide a variable degree of glide effect on pitch change programmed from the keyboard. Thus the input to the hold circuit may be routed direct or via a 1 megohm potentiometer with the switching accomplished by means of S1a/b. With the potentiometer set to maximum a time constant of 1 second is introduced into the charging of the hold capacitor and thus glide effects of greater than one second duration can be achieved.

ALTERNATIVE HOLD CIRCUIT

An alternative form of hold circuit which is being adopted for professional users of the Minisonic is to replace the 741 operational amplifier with a pin compatible device having f.e.t. inputs. Although rather more expensive to construct the circuit, shown theoretically in Fig. 2, offers the great advantage that drift is reduced to around 1mV/minute and that, apart from setting the output offset of the device to zero, there is no prolonged balancing procedure required.

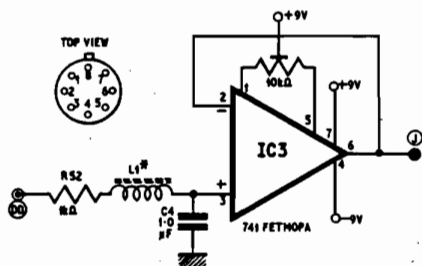

Fig. 2. Alternative form of hold circuit

The alternative circuit may be built on the main circuit board with a minimum of modifications in the way of wire links to bridge out the provision for the feedback balance preset. Constructors should note that both the hold circuits establish a d.c. output potential when the instrument is switched on for the first time and that these offsets can be of either positive or negative potential. When switching on therefore, allow a few moments for the circuits to

stabilise then depress one of the lower keys on the keyboard to set the hold circuit output to a voltage within the range of, and compatible with, the v.c.o.s.

V.C.O.s—CONTROL NODES

The v.c.o.s in the Minisonic Mark II have been the subject of a number of radical design changes and we will deal firstly with the control node. In the original Minisonic the option of temperature stabilisation was offered utilising a so-called transistor oven arrangement which had proved to be very successful in the P.E. Sound Synthesiser.

The oven, which provided stabilisation for both v.c.o.s and for the v.c.f., was constructed around a transistor array, the ML3046P by Microsystems International. In May of 1975 however Microsystems ceased production and it was necessary to utilise the RCA equivalent array, the CA3046. Unfortunately the characteristics of the CA3046 proved to be slightly different from those of the ML3046P the most serious

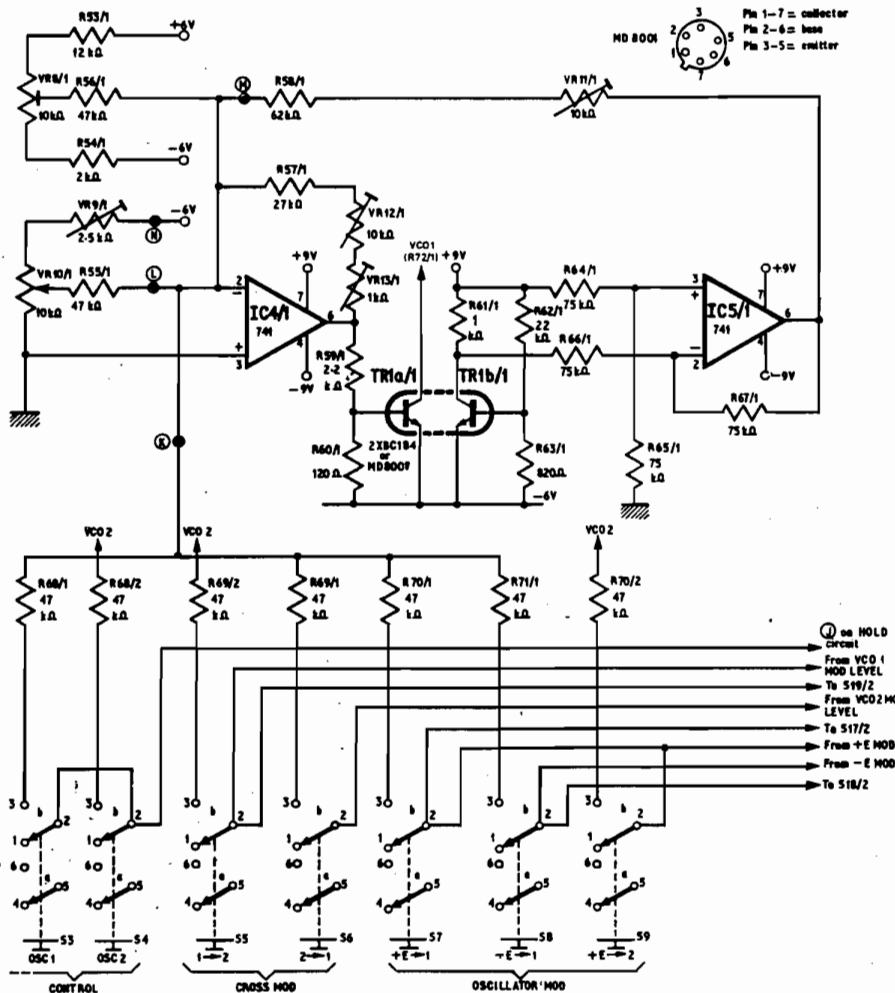

Fig. 3. Temperature compensated v.c.o. control node

COMPONENTS . .

VCO— CONTROL NODE (2 REQUIRED)

Resistors

R53	12kΩ
R54	2kΩ
R55	47kΩ
R56	47kΩ
R57	27kΩ
R58	62kΩ
R59	2.2kΩ
R60	120Ω
R61	1kΩ
R62	22kΩ
R63	820Ω
R64	75kΩ
R65	75kΩ
R66	75kΩ
R67	75kΩ
R68	47kΩ
R69	47kΩ
R70	47kΩ
R71	47kΩ
All ±5% 1/4W carbon	

Potentiometers

VR8	10kΩ preset
VR9	2.5kΩ preset
VR10	10kΩ lin.
VR11	10 turn W/W 20 turn
VR12	10kΩ preset 20 turn
VR13	1kΩ preset 20 turn

Semiconductors

IC4	741
IC5	741
TR1a/b	MD8001

difference being that the transistors would provide a true exponential function over rather less than one decade, approximately three octaves. In practice the degree of error introduced was about 0.25 per cent at the extreme of a three octave span and it was decided that this was rather too much to tolerate for really serious musical purposes.

The alternative form of temperature stabilisation adopted is shown in Fig. 3 and, although very simple in concept, it has been found, in practice, to work extremely well. Basically the idea is founded on the assumption that two transistors having identical gains, fixed bias characteristics and mounted in the same environment will behave in a predictably similar way in response to changes in temperature. It is known, for example, that the V_{be} of a transistor will tend to fall with an increase in temperature. If the bias is fixed however then an increase in temperature will cause an increase in current through the device.

If our two transistors are arranged such that one is employed as the controlled current generator for the v.c.o. and the other as a controller and the current in the controller is monitored with the resultant signal led back to the control node of the c.c.g. then, since both transistors behave in an identical manner, the feedback from the controller can be made to vary the bias on the c.c.g. in inverse proportion to changes in temperature. This is, essentially, the function of the circuit shown in Fig. 3.

CIRCUIT ACTION

IC4 is the control node which provides drive to the c.c.g., TR1a. TR1b is the controller which is biased by R62/1 and R63/1 such that it is passing about 0.5mA–0.75mA. The differential voltage across R61/1 is monitored by IC5 which has unity gain, thus the voltage output of IC5 will be in the range +0.5 to +0.75V. This value is not too critical since variations here can be compensated for by adjustment of VR8 in the control node.

The output signal of IC5 is led back to the control node IC4 via R58/1 and VR11/1 the total resistance value being adjusted such that the attenuation factor in relation to the feedback resistor value in IC4 is approximately 0.5. In other words the overall response of the system between the differential voltage across R61/1 and the output of IC4 is less than unity. The transistors TR1a and TR1b were, in the prototype Mark II, a pair of selected BC184s which were bonded face to face by means of a thin smear of Araldite.

To provide a better thermal contact and, at the same time, a degree of thermal inertia, three turns of tinned copper wire were bound tightly around the plastic bodies of the transistors and secured by twisting the ends tightly together. The use of a dual transistor such as the MD8001 undoubtedly improves the control characteristic but at a slight additional expense.

TEN TURN POTS

In the control node itself VR8 sets the bias on IC4 and fixes the lower frequency limit of the v.c.o. VR10/1 is the manual frequency control and it is recommended that this be a ten-turn precision pot.

VR9/1 adjusts the potential across VR10/1 such that it is precisely 5 volts. Since we will be setting up the control node such that the response or law is 500mV/octave this means that each turn of the potentiometer gives an octave change in frequency of the oscillator. It is recommended that each control node be constructed and set up individually before adding the oscillator components to the p.c.b.

During construction the following points should be observed. R58/1 should not be connected until the control node operating points have been established. VR12/1 and VR13/3 should be set to the mid point of their electrical travel before mounting.

It is recommended that these devices be 15–20 turn cermet presets. Although more expensive than the standard open types the greater precision in setting up and the ease with which this operation may be accomplished adequately compensates for the increase in cost.

When connecting VR10/1 temporarily to set up the control node it should be linked directly with its "high" end to the –9V rail and adjusted so that its wiper is initially at the earthy end of its travel.

SETTING UP

When assembly of a control node has been completed, except for the connection of R58/1, power may be applied and VR8 adjusted so that its wiper is around –0.5V potential.

Connect a microammeter between the collector of TR1a and the 0V rail with its positive terminal to the 0V rail. No reading should be discernible at this stage. Advance VR10 until the microammeter begins to indicate a flow of current through TR1a and adjust the pot until such time as the current reading is at a rational level, say 1 or 2 microamps. At this stage monitor the voltage on the wiper of the pot and make a note of the voltage/current relationship. Advance the pot so that its wiper voltage increases by 0.5 volts and again note the voltage/current relationship.

Repeat this procedure a further four times or until there is a table of at least six relationships. The aim is to achieve a doubling of the current through TR1a for each successive 0.5V increase in potential at the wiper of VR10 and the purpose of making a number of measurements initially is to accurately establish the error relationship in the control node.

ASSESSMENT

If, for example, there is less than a doubling of current between each successive voltage reading then the gain of the control node is too low. Conversely if the current more than doubles for each 0.5V increment in voltage then the gain is too great and, in either case, adjustment has to be made to the feedback resistance on IC4. If, for example, the gain is too great and for a 5.0V input the current is 16 μ A with an increase to 40 μ A at a voltage of 5.5 then the voltage should be set at 5.5 and VR12 adjusted so that the error is halved i.e. the current would now be 36 μ A.

Taking this as the datum level VR10 is now adjusted back in a series of steps of 0.5V until a new set of

readings has been established. VR12 should be adjusted again so as to halve the error and the procedure repeated until the error in current doubling is very small.

Final adjustments may then be made using VR13. When the required current doubling relationship has been achieved VR10 should be set so that its wiper is at -6 volts and VR8 adjusted so that the current through TR1a is 20 μ A.

Note that it may not be possible to quite get to 20 μ A at this stage since the positive voltage swing of VR8 is limited to compensate for the bias applied to the control node from IC5. If this is the case set the current through TR1a as close to 20 μ A as may be possible. A slightly moistened finger now placed on top of TR1a/b should result in an increase in the current reading.

FEEDBACK CONNECTION

R58 may now be connected having first adjusted VR11 so that it offers zero resistance. The effect of connecting R58 will be to apply a negative bias to TR1a thereby reducing the current. VR8 should therefore be readjusted until the current is 20 μ A as before. Again place a slightly moistened finger on TR1a/b and observe the effect on the current through TR1a. In this case since the gain factor is greater than unity the current through TR1a should decrease thereby implying too great a correction.

Allow the transistors to stabilise at room temperature and adjust VR11 to increase the resistance in the feedback loop and try the finger test again. This procedure should be repeated until there is no change in the current through TR1a or, at worst, only a very small change.

Note that the finger test is a very severe one and that, furthermore, if the finger is not applied squarely over both transistors in the pair then it is possible to impart a bias to either one or the other which, due to the thermal lag between the active junctions, may introduce an error into the procedure. The exercise of care and some patience is therefore required. Where a

COMPONENTS . . .

VCO—INTEGRATOR/COMPARATOR (2 REQUIRED)

Resistors

R72	1k Ω
R73	10k Ω
R74	20k Ω
R75	15k Ω
R76	470k Ω
R77	20kΩ 20k Ω
R78	47k Ω
R79	6.8k
All	=5% $\frac{1}{4}$ W carbon

was changed from 2k Ω , see next page.

Capacitors

C5	0.047 μ F polyester
C6-7	22 μ F tantalum 25V (2 off)
C8	0.1 μ F ceramic (VCO1 only)

Potentiometers

VR14-15	10k Ω linear
VR16	10k Ω linear (VCO1 only)

Semiconductors

IC6	741
IC7	LM318N
TR2	2N5459
D1	1N914 (VCO1 only)

dual transistor is employed there is, of course, no problem of thermal lag and the procedure is rather more straightforward.

If, when R58 is connected for the first time and the finger test carried out, the current through TR1a increases check first of all that the finger is being applied squarely to both transistors. If this is so monitor the output of IC5 during the period that the finger is applied to the transistors. As stated earlier the output of IC5 should normally be in the range 0.5V-0.75V positive and should become more positive as TR1b is warmed up. If this is also the case then the feedback from IC5 is insufficient and R58 should be reduced to the next lower preferred value, say 56 kilohms.

When temperature balance has been achieved check that the wiper of VR10 remains at -6.0 volts and finally adjust VR8 so that the current through TR1a is 40 μ A. No further adjustments need be made to the control nodes until the instrument is fully completed at which time the oscillators can be tracked aurally at mid range by means of small adjustments to VR13 and set to similar minimum operating frequencies by means of VR8.

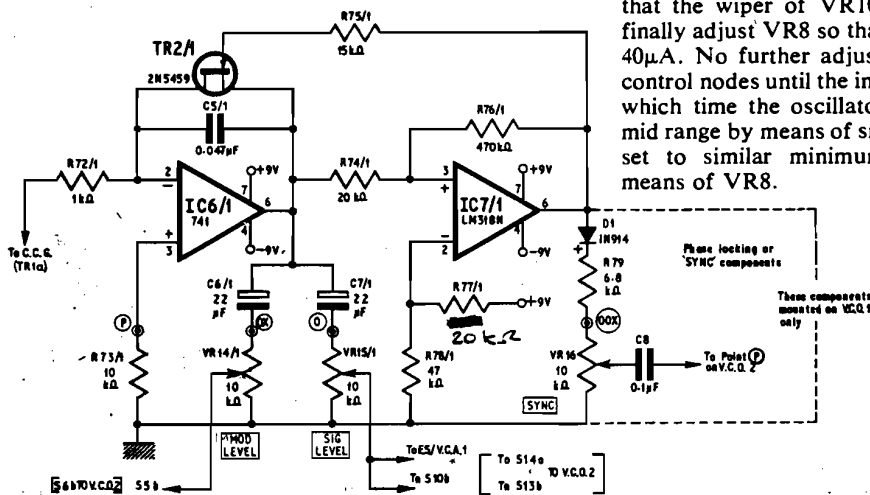

Fig. 4. Circuit of v.c.o.

OSCILLATOR SECTION

The v.c.o. illustrated in Fig. 4 comprises an integrator built around IC6, a comparator around IC7 and a reset switch TR2. In common with the control node the oscillator section introduces a number of fairly radical departures from the original design particularly around the comparator.

The original Minisonic v.c.o. was designed as a simple, low cost circuit and, as such, exhibited a number of features which are undesirable in an oscillator to be used primarily as a musical sound source. Basically the range of the original tended to be restricted by relatively slow switching rate of the comparator which, in that circuit, was a 741 operational amplifier.

Secondly the method of resetting the integrator was rather crude in that it depended on a fairly substantial current pulse being applied to the inverting input direct from the positive rail. Whilst effective, the arrangement introduced a peaky reset pulse on to the integrator output waveform which although too fast to be audible tended to introduce further problems if any attempt was made to synchronise the oscillators.

In the present design the latter problems have been overcome by replacing the 741 acting as comparator with the extremely fast LM318N, a device which has a specified slewing rate—in the feed forward mode—of 70V/microsecond i.e. it is some 140 times faster than the 741 it replaces.

Secondly the integrator reset is accomplished by a fast f.e.t. strapped across the integrating capacitor. In this design the width of the reset pulse is governed principally by the period required to discharge the integrating capacitor rather than the speed of the devices initiating the reset.

OPERATION

The operation of the circuit is as follows: the c.c.g. in the control node draws a constant current from the inverting input of IC6 thereby causing it to ramp in a positive direction. IC7 is held hard negative at this stage by the combined effect of the divider R77-R78 and positive feedback via R76 all of which establishes a threshold level. When the positive going ramp from IC6 exceeds the threshold level IC7 switches rapidly positive turning on TR2, discharging C5 and causing the output of IC6 to return to its minimum level again at which point the cycle repeats.

In order to achieve the fastest possible discharge of C5 it is necessary, in this circuit, for a fairly substantial potential difference across TR2 and thus the threshold level set by R77-R78 is around 6.3V. In practice this means that the integrator ramps about a point approximately +5V. It is therefore important that care is taken to correctly observe the polarities of the coupling capacitors C6 and C7.

With the component values given this oscillator produces an exceptionally clean waveform of nominally 1V peak-to-peak up to a frequency of about 50kHz-60kHz. If driven above this frequency the output waveform tends to take on a triangular shape as the rate of integration approaches the rate of reset.

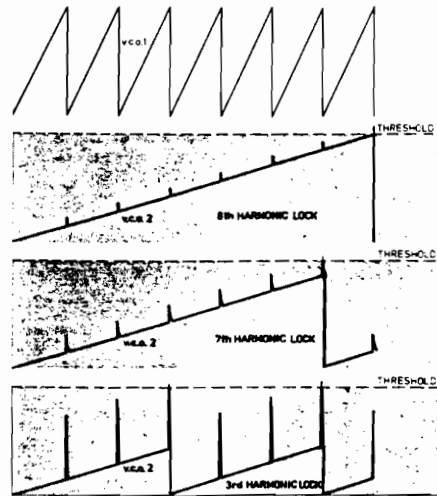

Fig. 5. Oscilloscope waveforms showing locking at different harmonics

Over the entire audio range however the output waveform is, for all practical purposes, a perfect sawtooth.

OSCILLATOR SYNCHRONISATION

In electronic organ circles there is a continuing dialogue as to the relative merits of phase locked or free phase operation. In the synthesiser it is generally accepted that the oscillators work in the free phase mode, indeed, some oscillator designs go to great lengths to avoid any possibility of phase lock occurring.

The success of free phase operation depends, in the synthesiser, very largely on the accuracy with which the matching of oscillator performance has been carried out. In the Minisonic Mark II it is demonstrably possible to match the oscillators within a few hertz over a range of three to four octaves. Above this the beats between the oscillators can become sufficiently fast as to create discords.

Some thought was thus given to the feasibility of providing a phase locking facility which could be used particularly for exercises involving the ring modulator where discordant beats in the oscillators also give rise to sum and difference discords thereby greatly accentuating the effect.

SYNC COMPONENTS

Referring to Fig. 4, phase locking is achieved by sampling the output of the comparator through a gating diode D1 and divider R79-VR16. The resultant positive going spike of maximum 4.75V is then applied to the non-inverting integrator input of the other v.c.o. The effect is to superimpose the spike on the output waveform of the other integrator as shown in Fig. 5 with the result that when the combined value of the ramp and spike exceeds the threshold level the second comparator will switch and restart the cycle.

Several interesting and useful effects are possible. Suppose, for example, that it is required to synchronise the oscillators at the musical interval of a fifth. The drill is to set VCO1, the oscillator supplying the sync pulse, to run at the lower frequency and to tune VCO2 to achieve a fifth. VR16 is then advanced—only a small movement will be needed—until phase lock is achieved. This point is clearly audible and characterised by a fixed beat difference between the oscillators. When now programmed from the keyboard both oscillators will stay in tight lock over their entire range.

Another method is to set VCO1 to run at about eight or nine times the frequency of VCO2 and again to apply the lock signal. Here again tight phase lock is achieved but, with the wide frequency difference between the oscillators, it is possible to apply a greater level of synchronising signal and achieve lock again at a lower harmonic.

At the lower harmonic the amplitude of the ramp portion of VCO2 integrator output waveform has been decreased since the synchronising signal is of greater level. A further increase in sync level reduces the harmonic ratio still further with a proportional reduction in ramp level until, at the extreme, phase locking in unison is achieved. Fig. 5 shows schematically how the locking at different harmonics appears on the oscilloscope.

ADVANTAGES OF PHASE LOCKING

It is perhaps superfluous to state that this facility greatly extends the versatility of the system. Phase locking in conjunction with the ring modulator can create a range of remarkably rich chords which, in turn, give the impression that the instrument has more than its two oscillators. Additionally, the ability to achieve lock at a high harmonic ratio means that, with the ring modulator, it is possible to build up a series of high order harmonics for the purpose of reinforcing "brassy" type sounds.

CROSS MODULATION

Another feature of the Minisonic Mark II is one taken from the P.E. Sound Synthesiser, that of enabling the oscillators to cross modulate one another.

The integrator output is sampled via C6 and level control VR14 and is switchable into the control node of the other oscillator. Since the output of the integrator is nominally 1V then each oscillator is capable of modulating the other over a range of two octaves. Although this is well below the modulation range of the P.E. Sound Synthesiser it is nevertheless sufficient to allow the formation of a whole series of harmonically rich waveforms.

On its own this facility enables the creation of a substantial range of sounds which are closely imitative of conventional acoustic instruments. In conjunction with the phase locking facility the range is still further extended.

In Fig. 4 VR14/1 provides the variable signal level for cross modulation—and for oscillator modulation of

the filter—while VR15/1 controls the audio signal amplitude.

H.F. OSCILLATOR

As was explained previously, the method of triggering the envelope shapers in the Minisonic comprises the application of a high frequency signal to the keyboard controller and thus to the divider resistors. The d.c. level and a.c. signal are extracted from the divider chain and presented to circuits which can detect, on the one hand, the d.c. level only and, on the other, the a.c. signal.

This particular method was indicated when the instrument was to have been operated by means of a stylus and presents the advantage that a single make contact only is required in the keyboard assembly.

The circuit of the h.f. oscillator is shown in Fig. 6 and is unchanged from the original P.E. Minisonic.

VR17 sets both the frequency and the amplitude of the h.f. oscillator output. As the slider of VR17 approaches the R80 end of its travel a greater level of positive feedback will be applied to IC8 thereby reducing frequency and increasing the amplitude of the output signal. The converse applies as VR17 is moved in the opposite direction. With the output of IC8 unloaded the waveform is effectively square gradually reducing to a more trapezoidal shape and ultimately to a triangular waveform as frequency is increased.

With the values given the oscillator will operate over the range 2kHz–250kHz with the optimal frequency for envelope shaper triggering being around 60kHz.

Setting of the oscillator frequency should be finalised during the instrument lining up stages since there is some room for adjustment around the optimal frequency particularly when the oscillator is loaded by the input circuitry to the keyboard controller and the subsequent loading of the divider by the hold capacitor.

These factors will affect the amplitude of the signal reaching the h.f. detector. Too low an amplitude and the detector will not trigger satisfactorily whilst too much and the detector will remain permanently on.

H.F. DETECTOR

The circuit of the h.f. detector is shown in Fig. 7. A 709 operational amplifier is chosen in order to obtain the benefit of the higher gain bandwidth of this device.

The 709 is connected as a follower having a gain of around 660 and is decoupled from the keyswitch bus by means of C11. C10 provides additional decoupling for the bus thereby ensuring that hum signals do not cause spurious triggering of the detector and thus the envelope shapers.

The output of IC9 provides drive to TR3 which, in turn is coupled to the envelope shapers through D3 and also to the hold isolator mentioned earlier through R88. Under quiescent conditions the output of IC9 is nominally zero volts and TR3 is off. An a.c. signal of sufficient level on the keyswitch bus will cause IC9 to follow with each positive excursion

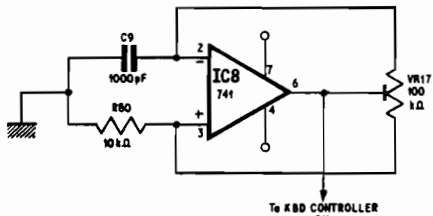

Fig. 6. Circuit of h.f. oscillator

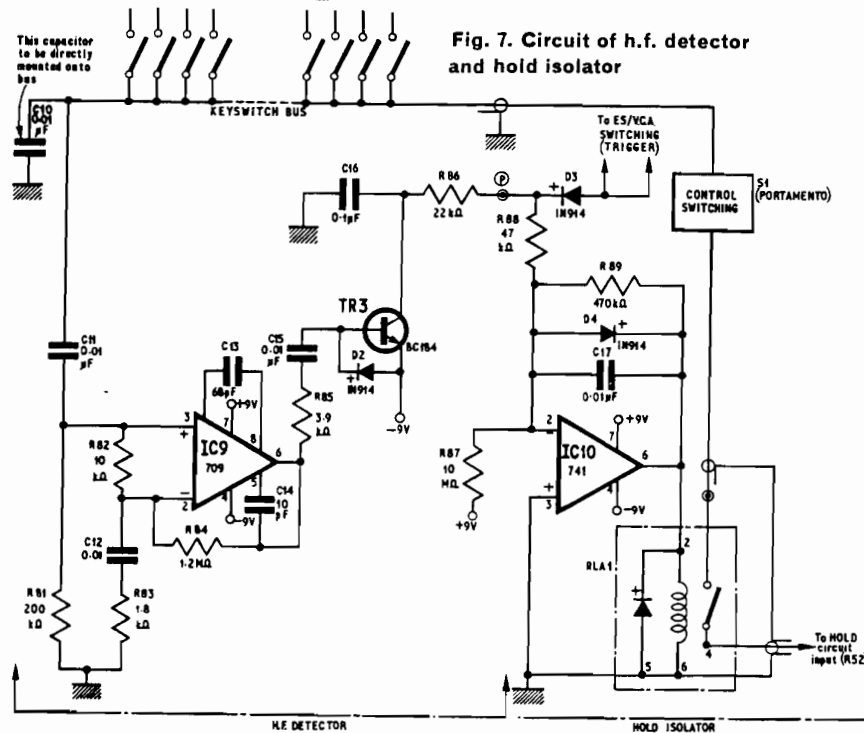

Fig. 7. Circuit of h.f. detector and hold isolator

COMPONENTS . .

HF OSCILLATOR / DETECTOR

Resistors
 R80 10kΩ R84 1.2MΩ
 R81 200kΩ R85 3.9kΩ
 R82 10kΩ R86 22kΩ
 R83 1.8kΩ
 All ±5% ¼W carbon

Capacitors
 C9 1000pF
 C10-12 0.01 ceramic
 C13 68pF
 C14 10pF silver mica
 C15 0.01μF ceramic
 C16 0.1μF ceramic

Potentiometers
 VR17 100kΩ preset

Semiconductors
 IC8 741
 IC9 709
 TR3 BC184
 D2 1N914

HOLD ISOLATOR

Resistors
 R87 10MΩ
 R88 47kΩ
 R89 470kΩ
 All ±5% ¼W carbon

Capacitors
 C17 0.01μF ceramic

Relay
 RLA1 Type A d.i.l. (R.S.)

Semiconductors
 D3-4 1N914
 IC10 741

of IC9 output turning TR3 on and causing the collector to go to about -8.5 volts.

During the negative going excursion of IC9 TR3 is off but the time constant of its collector capacitor is sufficient to maintain the negative level on the collector until such time as a further positive going signal is received from IC9. C16 thus acts in a smoothing capacity so that the collector of TR3 moves unipotentially in the presence of a triggering signal from IC9.

Correct functioning of the circuit may be checked by monitoring point "P" (Fig. 7) when the h.f. detector is connected to the envelope shapers. In these circumstances the bias which is holding the envelope shapers off is reflected as a potential of between +0.3 and +0.9V at "P". When the h.f. detector is triggered this voltage falls to around -2.2V.

THE HOLD ISOLATOR

The hold isolator circuit is a completely new addition to the original Minisonic. In the prototype keyboard instrument it was found that the relatively long length of wire between the keyswitch bus and the hold capacitor was sufficient to load the capacitor and

thus considerably increase the rate of drift of the hold circuit. Whilst this was of little importance during what might be termed normal playing of the keyboard it became much more significant when the very long decays of which this instrument is capable were being employed.

Essentially the circuit comprises an inverter having a gain of ten which drives a reed relay interposed between the keyswitch bus and the hold capacitor. Under quiescent conditions the inverter (IC10) receives positive inputs from R88 and R87 which combine to try and drive the output negative. A full negative excursion of IC10 is, however, prevented by D4 which limits the negative going output to around -0.6V.

When the h.f. detector triggers and point "P" goes to -2.2V IC10 will be forced into positive saturation thereby activating the relay coil and closing the switch. C17 in the feedback loop of IC10 provides additional smoothing so that any fluctuation of level at point "P" will not be reflected in the hold isolator circuit in terms of contact bounce of the relay.

The relay itself incorporates a diode to protect the driving circuitry against the back e.m.f. generated when the driving signal is removed.

COMPONENTS . .

ENVELOPE SHAPER (2 REQUIRED)

Resistors

- R90 75k Ω
- R91 3.9k Ω
- R92 560 Ω
- R93 20k Ω
- R94-95 1k Ω (2 off)
- R96* 10k Ω
- R97 10k Ω
- R98 8.2k Ω → 18k Ω (see text)
- R99 910 Ω
- R100 680 Ω
- R101 680 Ω
- R102 560 Ω
- R103 39k Ω
- R104 3.9k Ω
- R105 6.8k Ω (ES1 only)
- R106-7 6.8k Ω
- All $\pm 5\%$ $\frac{1}{4}$ W carbon

Potentiometers

- VR18 1M Ω log.
- VR19 250k Ω log.
- VR20 20k Ω -22k Ω preset
- VR21 25k Ω log.

Capacitors

- C18 10 μ F tantalum
- C19 1 μ F tantalum
- C20 0.1 μ F tantalum
- C20a/b 680pF ceramic/10 μ F tantalum

Indicator

- LPI miniature red i.e.d.

Fig. 8. Envelope shaper and voltage controlled amplifier. R* should be adjusted for 0.6V at P.

	TR4 BC184	TR6 BC184*	IC11 741
	TR5 BC213	TR7 BC184	IC12 MFC6040

Note: Items marked * are for proportional i.e.d. driving. If i.e.d. is to be driven from IC11 direct, these may be omitted and R99 changed to 750 Ω

ENVELOPE SHAPERS AND V.C.A.s

The theoretical circuit of the envelope shaper and voltage controlled amplifier is shown in Fig. 8. This circuit incorporates a number of modifications over the original Minisonic. Firstly the circuit around the integrator IC11 is very much simplified in that three diodes and one capacitor have been removed without significantly changing the operating characteristics of the circuit.

Secondly R*, originally a fixed value resistor, has been changed to a preset in order to ease the problem of biasing up the v.c.a. driving transistor.

Finally an i.e.d. has been incorporated into the circuit in order to provide a front panel indication of envelope state. Drive to the i.e.d. is through TR6 which is biased to a point just below conduction, when the envelope is in its most negative state i.e. -0.6V.

Additional components required for a Minisonic conversion are R96; R98; R99; LPI; TR6; R100 and D8 and the i.e.d. A simpler form of conversion is to drive the i.e.d. directly from the output of IC11. In this case the series resistor, R99 in the circuit given, should be 750 ohms.

It should be noted that if the latter form of conversion is employed there will be a propagation delay between the time that the envelope shaper starts its excursion and that at which its envelope level is sufficient to illuminate the i.e.d.

Additionally it is important that, if the direct drive system is employed, the i.e.d. chosen should be of the low current type.

E.S. OPERATION

The operation of the envelope shaper is as follows: IC11 is a linear integrator whose output voltage excursion is bounded in both negative and positive directions by the Zener diode D6. With the output of IC11 tending to go negative D6 acts as a normal diode such that the integrator output is held to -0.6V. As the integrator moves positively the output voltage is bounded to the limit set by the Zener voltage of D6. Thus the output voltage excursions of the integrator range between -0.5V and +4.5V.

In the quiescent condition R90; R91 and D5 set the bias on TR4 and TR5 such that TR5 is off and TR4 is on. Current reaching the inverting input of IC11 via TR4, R94 and VR18 charges C18 and thus, with the aid of D6, holds the integrator output at -0.5V.

When a negative going trigger signal is applied via R92 or R93 TR4 turns off and TR5 turns on. The charge on the integrating capacitor C18 thus leaks away via VR19, R95 and TR5 and the integrator output ramps in a positive direction until it reaches the bounded value set by D6. When the trigger signal is removed TR4 and TR5 revert to their original states and the output of the integrator ramps negatively until it reaches $-0.5V$. The rate at which ramping takes place, in either direction, is controlled by the value of the resistance in series with these latter transistors. Thus VR19 controls the rate of attack of the envelope and VR18 the rate of decay. Both these potentiometers should be of logarithmic law ideally since this type offers much better control when small changes in attack and decay rates are required close to the minimum values possible.

DIVIDER NETWORK

The integrator output is linked to a divider network R97-R101 to the base of TR7 which, with the output of the integrator at $0.5V$, is held at the point of conduction by means of a current supplied from the positive rail by means of VR20. The table in Fig. 8 gives the "on" and "off" d.c. conditions around TR7 and VR20 should be adjusted so that these conditions are met as closely as possible.

The setting of VR20 is quite critical since too much conduction in TR7 in the quiescent envelope state will mean that the gain/attenuation range of the v.c.a. is restricted with the possible result that signal breakthrough will be present. Too little conduction on the other hand will result in a propagation delay between the onset of an envelope and the appearance of the audio signal at the output of the v.c.a. Thus fast attack times would not be possible in this latter condition since the produced sound would be of very short duration and severely attenuated.

E.S. TRIGGERING

Triggering of the envelope shapers can be accomplished in a number of ways, Fig. 9 indicating the arrangement of switching for the trigger signals. Envelope shaper VCA2 is permanently linked to the output of the h.f. detector and thus this circuit will always be operational whenever keys are depressed on the keyboard.

Envelope shaper VCA1 can also be triggered from the keyboard when S21 is closed. Additionally this latter circuit may also be triggered via S22 and S23 the "Hold" and "Trigger" buttons respectively.

With S21 open, closure of S22—a latching switch—will ensure that the envelope shaper is in the "on" condition and that signals to its related v.c.a. will be audible whatever is happening to the keyboard.

S23 is a momentary action switch. With S21 open, closure of S23 will create an envelope and make audible any input signal to VCA1 in addition to signals from VCA2 which are programmed through from the keyboard. Methods of use for these trigger switches will be described in a later section of this article.

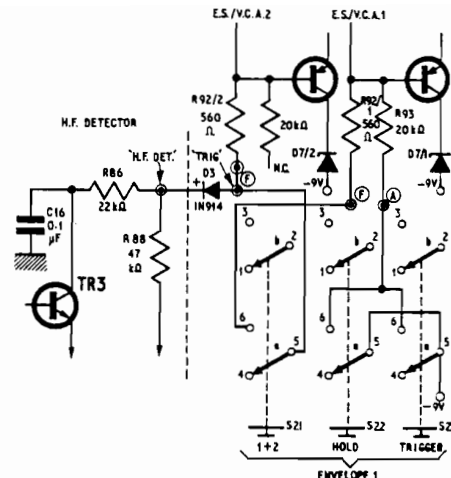

Fig. 9. Arrangement of switching for the E.S. trigger signals

Note that operation of either S22 or S23 will not affect the hold isolator since D3 provides a gating action in this respect.

ELECTRONIC ATTENUATOR

The v.c.a., or to give it its proper title, electronic attenuator, is a purpose designed i.c. by Motorola.

The specification of the device is to provide an attenuation of 77dB and a gain of 13dB relative to the input signal which should not exceed 500mV r.m.s., when the current sink from the control input (pin 2) is varied from minimum to maximum respectively. In the Minisonic II the relatively low operating voltages result in a reduction of the overall attenuation/gain range to about 54dB which is sufficient for most practical purposes.

The current sink from pin 2 of IC12 is, in the off condition, restricted by the series combination of R103 and R104. As TR7 turns on it progressively short circuits R103 with the result that the current sink increases proportionately to a maximum which is limited by R104. It should be mentioned, of course, that the linear envelope of IC11 is converted into a negative exponential characteristic by TR7.

Although this is not ideal for an audio signal envelope, experience has shown that it is extremely difficult to differentiate subjectively between a negative exponential and a positive exponential, or square law, envelope which is considered to give the best effect.

SIGNAL ROUTING

Having given consideration to the v.c.o.s and envelope shaper v.c.a.s which are the mainstays of the audio signal system in the Minisonic we will now look at the methods of signal routing between them.

Any method of switched patching arrangement between signal sources and treatments is bound to be somewhat restrictive when compared with a "free-for-all" patchcord system which enables virtually any module combination to be made. In the Minisonic II therefore very careful thought has gone

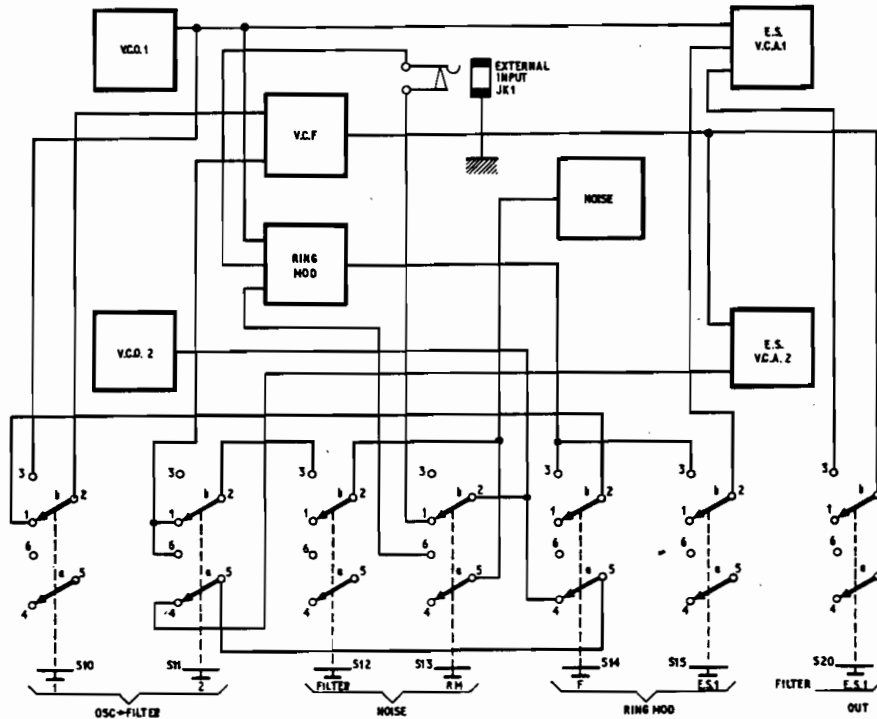

Fig. 10. Arrangement of signal switching

into the switching options available with the view of combining maximum flexibility with the simplest possible arrangement of switches. Fig. 10 illustrates the system finally adopted.

The first thing to remember is that all signals reaching the output stages of the Minisonic have, first of all, to pass through the v.c.a.s in which they are modified by the envelope characteristics. This applies equally to signals which originate in the instrument or those which are supplied from external sources through the input breakjack.

In the case of VCO1 the output signal is routed directly to envelope shaper/VCA1 and also to the ring modulator. An indirect link is provided by means of S10 which enables VCO1 signal to be routed into the voltage controlled filter (v.c.f.).

From VCO2 the output signal can only reach its related envelope shaper/v.c.a. by an indirect route via S11. With this latter switch in one position VCO2 signal goes direct to its v.c.a. whilst, in the other, the signal is routed into the voltage controlled filter. VCO2 signal is also routed to the ring modulator via S13 and the input breakjack.

VERRIDE

Thus the application of an external signal into the breakjack will override the routing and, similarly, closure of S13 will override VCO2 signal into the ring modulator and substitute that of the noise generator.

Both the noise generator and ring modulator output signals can be routed into the filter but only through

S10 and S11. The oscillators thus take precedence as far as filtering is concerned and operation of either S10 or S11 will respectively override the ring modulator and noise generator.

Finally, the filter output is linked directly to envelope shaper/VCA2 and can, in addition, be linked to envelope shaper/VCA1 through S20. The ring modulator output has two output routing options, to the filter through S14 and/or to envelope shaper/VCA1 through S15.

Some consideration of the foregoing in combination with Fig. 10 will show that it is possible to ring the changes in terms of output signal combinations and over quite a wide range. Furthermore, since each switch provides an "either/or" arrangement the system as a whole presents a flexible and rapid means of changing from one signal form to another.

VOLTAGE CONTROLLED FILTER

The v.c.f. is perhaps the most useful of the signal processing circuits in any synthesiser. Its principal function is to vary the passband of signals passing through the circuit thereby proportionally varying the harmonic content of complex signals.

Whilst it is possible to apply a fixed passband characteristic to the filter it can also impart a tracking capability such that a succession of musical tones from anywhere in the audio range will have the same, or closely similar, harmonic content. Furthermore it is also possible to vary the passband during the audible period of a signal such as to impart an amusing characteristic to the sound. Each of these

methods of operation finds an important niche within the tone colour spectrum of the synthesiser.

The v.c.f. is a two part circuit comprising a control node similar in form to that used in the v.c.o. and a ladder network in which the filtering action takes place.

CONTROL NODE

Fig. 11 illustrates the control node. Although quite similar to the control node of the v.c.o.s there are nevertheless some important differences. The first is that temperature compensation has been abandoned since it has been found that stability in this respect is not of prime importance. Secondly the number of modulation sources has been greatly increased and, since these can be operated in any combination, it is necessary to provide some form of current limitation so that the filter does not overload the reference voltage supplies.

For Minisonic conversions the additional components required are: D10; R112; VR24; and R116-R118.

IC13 is an inverting amplifier which provides drive to a constant current generator TR8. The gain of the amplifier is prescribed by adjustment of VR24 and VR25 which give fine and coarse control respectively. D10 provides a limit to the output of IC13 and therefore sets a limit to the current through TR8. The effectiveness of D10 in this respect depends to a certain extent on the gain of TR8 and also on the absolute value of the Zener voltage.

SETTING-UP

The setting-up follows similar lines to that of the v.c.o.s in that the gain controls VR24 and VR25 are adjusted so that each 500mV increment of control voltage applied by VR23 will result in a doubling of the current through TR8. With a control voltage of -6V at the wiper of VR23 the bias control should be adjusted so that the current through TR8 is a maximum of 10 μ A.

Advance the frequency control VR23 so that its wiper voltage is at -9V. The output of IC13 should now be the sum of the wiper voltages at VR23 and VR22 times the gain constant of IC13 which is around 0.69. In other words the output of IC13 will be in the region of +6.0V \pm 0.25V.

Under these conditions the current through TR8 will be around 2.5mA but bear in mind that due to the self-heating in the transistor this current will gradually increase until the heating effect of the current is balanced by the heat loss from the transistor body. It is prudent therefore to make the current measurement early in the proceedings.

A second control voltage potentiometer should now be connected temporarily as for VR23 and its wiper linked into the inverting input of IC13 through a 47 kilohm resistor. With the wiper initially at the earthy end and a wary eye on the milliammeter monitoring current through TR8 advance the wiper until either the current through TR8 reaches 10-12 milliamps or, until the output of IC13 limits at +7.5 volts.

COMPONENTS . . .

VOLTAGE CONTROLLED FILTER

Resistors			
R108-109	6.8k Ω (2 off)	R121	390 Ω
R110-111	47k Ω (2 off)	R122	1k Ω
R112	27k Ω	R123	390 Ω
R113	2.2k Ω	R124	1k Ω
R114	120 Ω	R125	15k Ω
R115-118	47k Ω (4 off)	R126	20k Ω
R119-120	2.2k Ω (2 off)	R127-128	470k Ω (2 off)

All \pm 5% $\frac{1}{4}$ W carbon

Capacitors	
C21-22	10 μ F tantalum (2 off)
C23-26	0.047 μ F polyester (4 off)
C27-28	10 μ F tantalum (2 off)

Potentiometers			
VR22	10k Ω preset	VR26	10k Ω preset
VR23	10k Ω linear	VR27	10k Ω log. or lin.
VR24	1k Ω preset (20 turn)	VR28	1k Ω linear
VR25	10k Ω preset (20 turn)		

Semiconductors	
D10	7.5V 400mW Zener
D11-D22	1N914 (12 off)
TR8-TR10	BC184 (3 off)
IC13	741
IC14	741

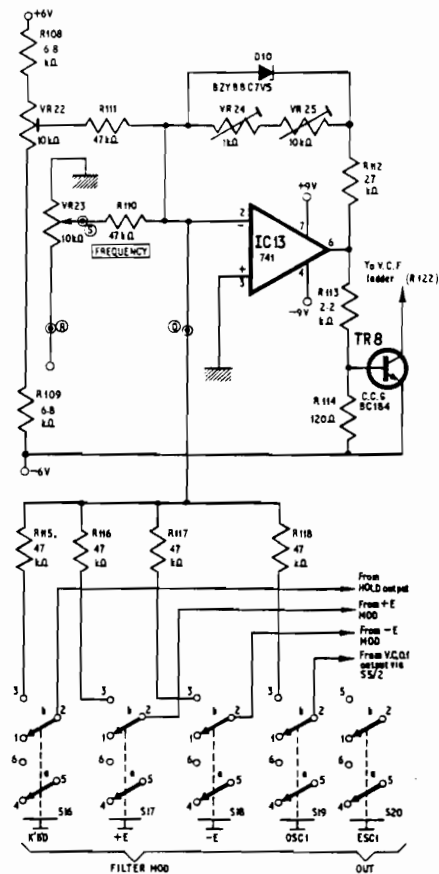

Fig. 11. V.c.f. control node

Practical Electronics Sound Design

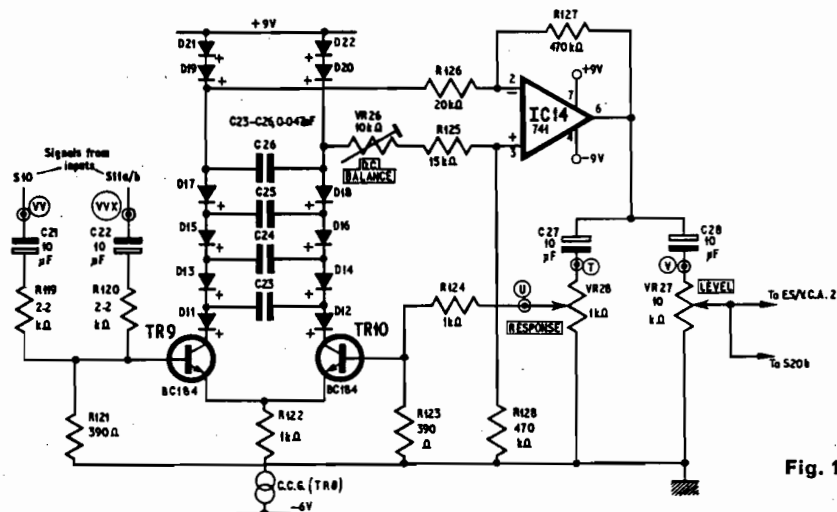

Fig. 12 Low-pass filter ladder network

INTERPRETING THE MEASUREMENTS

If both these measurements are noted to occur at the same time then all is well and further advances to the second control voltage potentiometer will not increase the current through TR8. If, however, the current reaches its maximum figure before IC13 limits then the value of D10 will have to be reduced to, say, 6.8V.

In the event that the 6.8V limitation prevents the maximum current of 10-12mA being achieved then there are two courses of action possible. If the current discrepancy is small, i.e. less than 0.5mA then it can be ignored. Where the discrepancy is around 1mA or more a resistor can be placed in series with D10 and adjusted in value as necessary until, with IC13 limiting, the current through TR8 is close to the specified value.

Having made the above adjustments any further increases in control voltage will have no effect on the current generator and the upper limit of operation has been set. It now remains to increase the minimum current so as to fix the lower operating point.

For this adjustment the temporary control potentiometer should be removed and the wiper of VR23 returned to the earthy end. VR22 should now be adjusted so that the minimum current through TR8 is around 35µA to 40µA.

LOW PASS FILTER

The theoretical circuit of the low-pass filter ladder network is shown in Fig. 12.

The ladder itself comprises a series of diodes in combination with capacitors. The diodes present an impedance which varies inversely as the current through them. In other words at low levels of current the impedance is high and vice versa. Thus, as the current through the ladder is varied, the effective resistance in combination with each capacitor will also vary and thereby change the turn-over frequency of each separate combination.

The ladder terminated in transistors TR9 and TR10 which are effectively biased on by referring their

bases to the 0V rail. Thus any current drawn through the network by means of the c.c.g. will pass, without restriction, through these transistors.

An audio signal applied to the base of TR9 will, however, create a proportional variation in the current through the transistor and thus also a voltage variation at each diode junction in the ladder. This applies virtually to every value of current drawn by the c.c.g. so that, for a given level of a.c. signal, the smaller the current through the network the smaller will be the proportional variation induced by the signal. Thus the concept of variable impedance is, in fact, due to a combined effect of diode, transistor and current generator.

SEVERAL DECADE RANGE

The circuit has a range which extends over several decades and, as shown, the -6dB passband is, at maximum, from nominally 3Hz to 15kHz.

Four filter stages are cascaded in the ladder network and since each stage has a theoretical roll-off of 6dB/octave the maximum roll-off of the filter should be 24dB/octave. Efficiency in this respect however can only be achieved if every precaution is taken to prevent loading of the network at the point of entry and the point of extraction of the audio signal. In the interests of simplicity and economy buffer stages have not been included in this circuit but, even so, the roll-off possible is around 12dB-15dB/octave.

The output from the ladder network is amplified differentially by IC14 with VR26 being employed to minimise any d.c. imbalance caused by variations in diode characteristics. Such variations can be minimised at the outset by individually selecting the diodes such that each pair presents identical forward voltage characteristics. Even so it will be found that there is a degree of d.c. offset appearing at the output of IC14 when the ladder current is increased from minimum to maximum. VR26 should therefore be employed to centre the offset about zero volts such that when the filter is operating around midrange the d.c. output of IC14 is zero.

OUTPUT

The output from IC14 is capacitor coupled into two potentiometers. VR27 is simply the output level control while VR28 is the feedback or "Q" control. VR28 may also be referred to as the "Response" control. With VR28 wiper at zero volts the base of TR10 is referred closely to the 0V rail and thus TR9 and TR10 behave essentially as a differential pair. The output of IC14 is therefore nominally in phase with the input signal at the base of TR9.

As VR28 is advanced from zero a proportion of the output signal appears at the base of TR10 thereby tending to induce a signal in the collector circuit which is oppositely phased with the signal already present due to the effect of the input signal on TR9. The result is that the output signal will become significantly attenuated except at the frequency whose period is equal to the adjusted time constant of the network.

At this critical frequency the output of the filter will peak up with the bandwidth of the signal depending largely on the degree of feedback applied.

Further application of feedback will cause the filter to oscillate. The frequency of oscillation is proportional to the current through the ladder network and the oscillation, which is of sine form, will be superimposed on the filter output signal. With the current limits quoted for the revised control node design the filter oscillates from around 2kHz to greater than 30kHz.

FILTER CHECK-OUT

Checking filter performance can most effectively be carried out after assembly of the complete instrument. For this purpose the audio output of VCO2 should be patched into the v.c.f. by means of S11 with the monitoring signal for headphones or external power amplifier being taken from channel 2. Initially the v.c.f. frequency and "Response" controls should be at zero and VCO2 set to run at a middle range audio frequency.

Advance the v.c.f. frequency control to maximum. As this is done the v.c.o. signal should become audible in the monitored channel rising from a fairly bland sound to the full harsh bite of the sawtooth waveform as the frequency control of the v.c.f. approaches its maximum setting.

Repeat this procedure with the "Response" control at both extremes. With "Response" at minimum the overall level of the sound should be somewhat greater than when it is at maximum but there will be less subjective change in the harmonic content of the resultant sound.

The next procedure is to check out the effect of automatically programming the v.c.f. signal. Advance ES1 attack and decay controls to approximately one third of their rotation. Connect by closure of S17, the output of the control envelope inverter into the control node of the v.c.f. Set the "control + envelope" level about halfway.

Closure of a keyboard contact will now result in a slow rise in audibility of the sound together with a distinct change in harmonic content as the sound becomes louder.

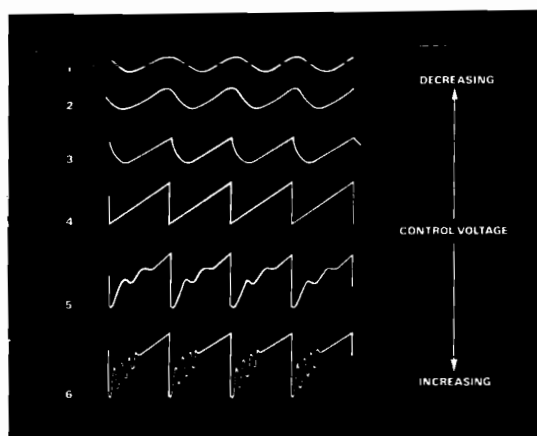

Fig 13. Effect of v.c.f. on a sawtooth voltage

Try various settings of the attack, decay and envelope level controls to achieve a typical synthesiser "Waa-Waa" effect.

USES OF THE V.C.F.

There are three principal ways in which the filter may be used as a sound treatment, of which two have been examined during the check-out procedure. Before going into these in any detail however let us look for a moment at what exactly it is that the filter does to the sawtooth waveform.

Fig. 13 illustrates a number of waveforms with the filter control voltage at different levels. In stage one the control voltage is very low i.e. with the frequency control just off the minimum end stop. If the sawtooth signal is around 1kHz say, the effect of the filter is to remove virtually all the upper harmonics leaving the fundamental which is almost of sine form.

Stage two and three illustrate the situation which occurs when the control voltage is increased successively; in each case the output waveform is assuming more of the sawtooth characteristic albeit still severely rolled off.

In stage four the control voltage is such as to allow the filter to admit the whole of the sawtooth without any roll-off.

RESPONSE CONTROL

The degree of roll-off of the filter is affected very largely by the amount of feedback admitted to the ladder network by means of the "Response" control. With "Response" at minimum the roll-off is much less accentuated and, indeed, the signal level from the filter is significantly greater than when the "Response" is at maximum.

Thus, with the "Response" at minimum the filter can act very much in the same way as a tone control i.e. passing all those frequencies lying below that set by the control voltage and rolling-off all those which lie above the set value at around 6dB per octave.

Increasing the feedback above a critical point will induce the filter to commence self oscillation.

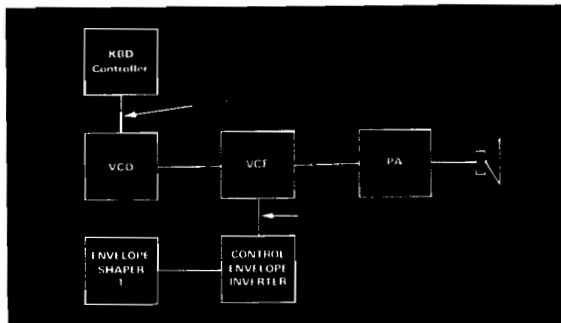

Fig. 14. Method of patching to achieve a v.c.a. or Waa-Waa

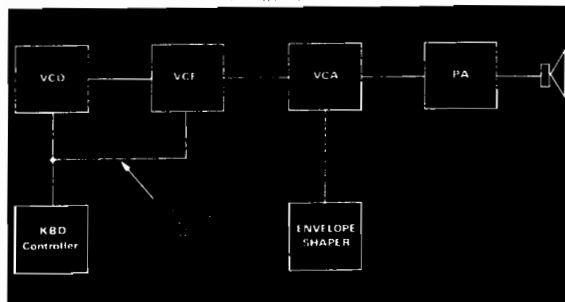

Fig. 15. Patch for v.c.f. to track the frequency of the v.c.o.s

Similarly when operating at high Q the filter will also begin to oscillate when the control voltage is advanced beyond a point where the input signal is wholly accepted. This situation is illustrated in stages five and six of Fig. 13, the frequency of oscillation being proportional to the increase in ladder current.

What applies, in general terms, to the changes occurring in a sawtooth waveform also applies to other waveforms which are rich in harmonics. In the case of a sine wave input however the effect of the filter is simply to cause a variable degree of attenuation to the signal in a manner dependent on the input frequency, control voltage and "Response" control settings.

USING THE FILTER AS A V.C.A.

Fig. 14 illustrates schematically the method of patching to enable the filter to act as an automatic Waa-Waa or as a voltage controlled amplifier.

In this case the positive output of the control envelope inverter is patched into the control input of the filter by closure of S17. The "Attack" control of ES/VCA1 should be at its minimum setting and the decay control at maximum.

Set the inverter level control about midway with the attack and decay controls of ES1 set about one third of their full rotation.

Close a key contact momentarily and when the resultant sound has decayed away—say in four or five seconds—adjust the frequency control of the filter so that the v.c.o. signal is just barely audible.

The keyboard may now be played in the normal way during which time the attack, decay and control envelope controls may be adjusted to achieve the

desired effect. Note that the greater the level of the control envelope the harsher will be output signal when the envelope is at its peak.

An inverted Waa-Waa effect can be achieved by setting the filter frequency control to maximum and using the negative going envelope to programme the filter by closure of S18.

TRACKING THE V.C.O.s

With the arrangement of patching as shown in Fig. 15 the filter may be used to track the frequency of the v.c.o.s. This is because the control input of the filter is directly linked to the output of the hold circuit and thus variations in this level will adjust the passband of the filter.

This method of operation is particularly useful if the instrument is being used in an imitative sense or if the constructor wishes to achieve a softer, harmonically reduced output signal. With this mode, the keyboard should be played at the same time adjusting the filter frequency and "Response" controls until the desired sound is achieved.

It will be found that a number of acoustic instruments can be effectively imitated using this method. For example, wind instruments such as the horn and trombone, string instruments such as the violin and cello and a clarinet tone have all been successfully synthesised with the Minisonic.

THE FILTER AS A TONE CONTROL

In the previous method of operation the passband of the filter was continuously being adjusted as the keyboard was being played such that the proportion of harmonic roll-off was effectively constant regardless of the frequency of the input signal.

If switches S16-S19 are all opened, the v.c.f. passband is now entirely dependent on the setting of the manual frequency control. With this at maximum the filter will pass frequencies up to 15kHz (-6dB) more, in fact, than the Minisonic would normally produce in a strictly musical sense.

With the frequency control near its minimum setting the -6dB passband is only 3Hz and thus the greater part of any filtered musical signal from the v.c.o.s would not reach the power amplifier stages.

The filter is now acting as a treble cut system with the degree of cut obtainable being varied by the "Response" control. With this at minimum the roll-off is about 6dB per octave and at maximum about 15dB per octave.

THE RING MODULATOR

The Minisonic ring modulator is an improved version of the circuit which originally appeared in the *P.E. Sound Synthesiser* (August 1973). The essential features of the circuit is shown in Fig. 16.

The ring modulator produces a unique output waveform which comprises, at the same instant, the sum and difference between any two applied input frequencies. This function is carried out in a purpose-built integrated circuit, the SG3402. Both the "N" or "T" packages of this device are suitable.

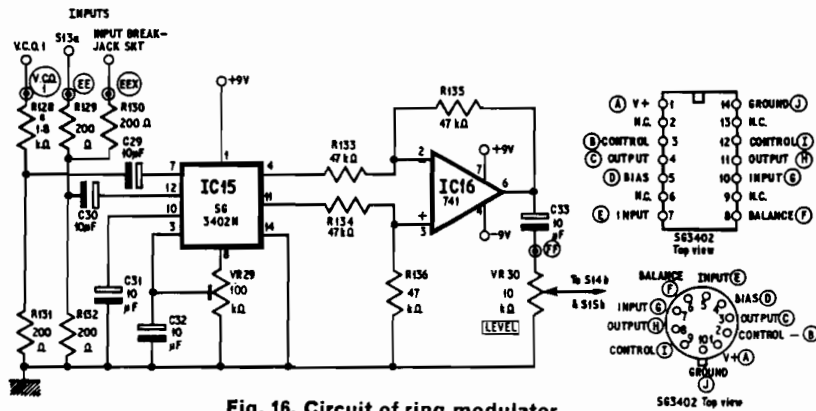

Fig. 16. Circuit of ring modulator

COMPONENTS . . .

RING MODULATOR

Resistors

R128a 1.8k Ω
 R129-132 200 Ω
 R133-136 47k Ω
 All $\pm 5\%$ $\frac{1}{4}$ W carbon

Capacitors

C29-33 10 μ F tantalum

Potentiometers

VR29 100k Ω preset
 VR30 10k Ω log.

Semiconductors

IC15 SG3402 "N" or "T"
 IC16 741

With one of the input frequencies fixed, variation in the other will ring the changes in the output frequencies as shown in Table 1.

Referring to Fig. 16, R128 and R131 form an input attenuator on the so-called carrier input (pin 7) such that, when driven from a v.c.o., the input signal level at C29 will be about 40mV to 80mV.

Similarly R129 and R132 attenuate the modulator or control input so that, when driven by a v.c.o., the input at C30 is about 200mV to 500mV. This procedure results in an output signal of about 1.5 volts at pin 4 and the same signal in antiphase at pin 11. The antiphase signals are amplified differentially by IC16 to give a peak output signal of three volts which is then applied via C33 to the level control VR30.

SETTING UP THE RING MODULATOR

Setting up the ring modulator is very simple. With the circuit completed, link the modulator input to the 0V rail and connect the output to a suitable power amplifier. Apply a signal of about 1kHz to the carrier input (normally connected direct to VCO1) and adjust VR29 until the output signal reduces to the lowest possible level. This should, with a correctly wired circuit, be 50dB or more below the peak signal level. At this point the ring modulator is correctly balanced with minimum carrier breakthrough.

MINOR CHANGES

The Minisonic II ring modulator features two minor changes from the original circuits. The first is provision of a second "modulator" input via R130 which leads to the external input socket. Secondly, the attenuating resistors on the output of IC16 have been removed to give a greater signal level. These were R9 and R10 in Fig. 3.7 of the original Minisonic articles.

TESTING THE RING MODULATOR

Patch the ring modulator output into envelope shaper VCA1 by closure of S15. VCO1 is connected directly to the ring modulator and similarly VCO2 is connected into the ring modulator through S13 and the external input breakjack (see Fig. 10).

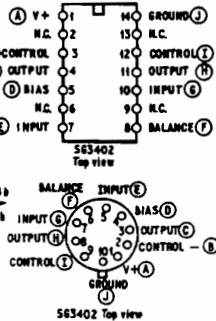

With both v.c.o. level controls at about three-quarters setting, set their frequencies manually such that there is a low beat frequency discernible from the ring modulator. Listen carefully for this because the output of the ring modulator is being mixed with the output of VCO1 in VCA1. Turn the level control on VCO2 to zero. At this point the beat frequencies should entirely disappear.

Route the output of the ring modulator into the v.c.f. by closure of S14. The v.c.f. frequency control should be at maximum and the response control at minimum. The level control of VCA2 should also be at maximum.

With these settings the output signal of VCO1 should not be discernible in channel 2. If it is detectable then there is some signal breakthrough in the ring modulator and VR29 should be re-adjusted to minimise this effect.

Make sure that the panning controls (Fig. 18) are hard left and hard right respectively for this test otherwise the breakthrough detected could prove to be panned signal.

USING IT

In a musical sense the ring modulator can be used to produce rich chord structures. For example, with both oscillators tuned apart by the interval of a fifth, i.e. the frequency of one oscillator is 1.5 times the frequency of the other, the output of the ring modulator will be, in the case of the sum frequency 2.5 times, and in the case of the difference frequency 0.5 times the frequency of the oscillator producing the lowest pitch.

Frequency	100	200	300	400	500	600
Carrier	700	800	900	1000	1100	1200
Modulator	200	300	400	500	600	700
Sum	100	200	300	400	500	600
Difference	300	200	100	0	100	200

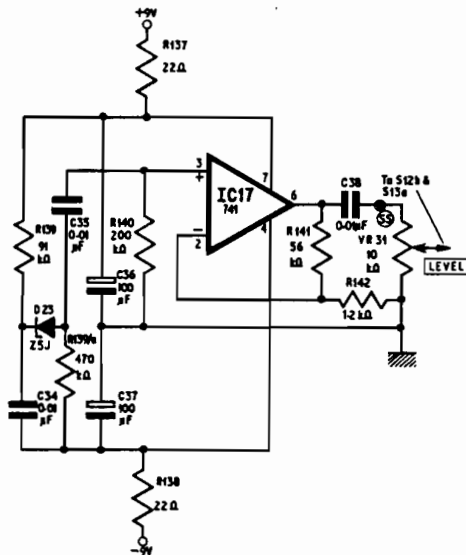

Fig. 17. Circuit of noise generator

If the output of this latter oscillator is taken as being the fundamental, then the output of the ring modulator may be said to comprise the sub-octave and twelfth with respect to the fundamental.

If this signal is now mixed with the outputs of the v.c.o.s originating the signals then the end result is a musically concordant four note chord.

Similar effects may be obtained when the oscillators are in unison, an octave apart or, as was explained in a previous section, tuned wide apart in phase lock. In all cases the richness of the resultant sound quite belies the simplicity of the system producing it.

OTHER RING MODULATOR EFFECTS

Apart from its musical possibilities the ring modulator may be extensively used in the production of sound effects. For example, with white noise patched into its uncommitted input (closure of S13) and with VCO1 running at low frequency—say around 10Hz—the reset point of the sawtooth will be differentiated by the ring modulator input decoupling capacitor such that the output of the ring modulator will comprise a series of staccato cracks akin to machine-gun fire. Filtering of the output signal can ring the changes quite widely over this one, very simple sound.

Dalek type voices can be produced by patching a crystal microphone or a pre-amplified magnetic microphone signal into the external input socket. A range of effects may be achieved by varying the frequency of the v.c.o. between about 20Hz and 1kHz bearing in mind that the greater part of the resultant audio signal will be derived from this oscillator.

A previously taped signal may also be connected into the external input socket and ring modulated with musically programmed v.c.o.s in order to produce some really weird and exotic sound forms.

COMPONENTS . . .

NOISE GENERATOR

Resistors			
R137-138	22Ω (2 off)	R140	200kΩ
R139	91kΩ	R141	56kΩ
R139a	470kΩ	R142	1.2kΩ
All ±5% ¼W carbon			

Capacitors	
C34-35	0.01μF ceramic (2 off)
C36-37	100μF elect. 25V (2 off)
C38	0.01μF ceramic

Potentiometers	
VR31	10kΩ log.

Semiconductors	
D23	Z5J (Z1J)
IC17	741

WHITE NOISE GENERATOR

The noise generator is a very simple circuit built around the highly successful Z1J (now Z5J) noise diode manufactured by Semitron Ltd. The circuit is shown in Fig. 17 and comprises the noise diode D23 whose output drives a high gain amplifier IC17. Output from the amplifier is decoupled by C38 and led to its level control VR31. The maximum output from this circuit should be around 2V peak-to-peak but variations may occur as a result of differences in the characteristics of the noise diode. If the output is significantly below the specified maximum some reduction in the value of R139/a may be tried with the view of increasing the current throughput of the diode.

If this does not appear to have any effect then the gain of IC17 may be increased by reducing the value of R142. In circumstances where the gain may have to be substantially increased there is a danger that drift in IC17 may impart a d.c. offset at the output which results in clipping of the noise signal. In these circumstances R140 should be reduced sufficiently to overcome the effect.

Under normal circumstances the noise generator should not require any special setting up procedures.

OUTPUT STAGES

The principal change in the output stages of the Minisonic relates to the inclusion of panning controls by means of which the respective outputs from the voltage controlled amplifiers may be mixed to create a stereo image. Additionally, the gain of the mixers has been increased to times 2 to fulfil the requirement for a stronger signal at the output.

The circuit of the output stages appears in Fig. 18. VR32a/b-1 and VR32a/b-2 are the panning controls. Although linear potentiometers are employed a log-antilog characteristic is imparted by the addition of resistors R143 and R144 strapped between the high end of each track and its respective wiper. The signal transition between one channel and the other is therefore accomplished very smoothly.

COMPONENTS

OUTPUT STAGES (2 REQUIRED)	
Resistors	
R143-144	22k Ω
R145-146	47k Ω
R147	100k Ω
R148	1.5k Ω
R149	910 Ω
R150	1k Ω
R151	4.7k Ω
R152	10k Ω
All = 5% $\frac{1}{4}$ W carbon	
Capacitors	
C39	4.7 μ F tantalum
C40	3,300pF polystyrene
C41	470 μ F elect. 25V
C42	0.005 μ F ceramic
Potentiometers	
VR32a/b	100k Ω lin. ganged
VR33a/b	10k Ω log. ganged
(1 only required)	
Semiconductors	
IC18	741
IC19	MFC4000B

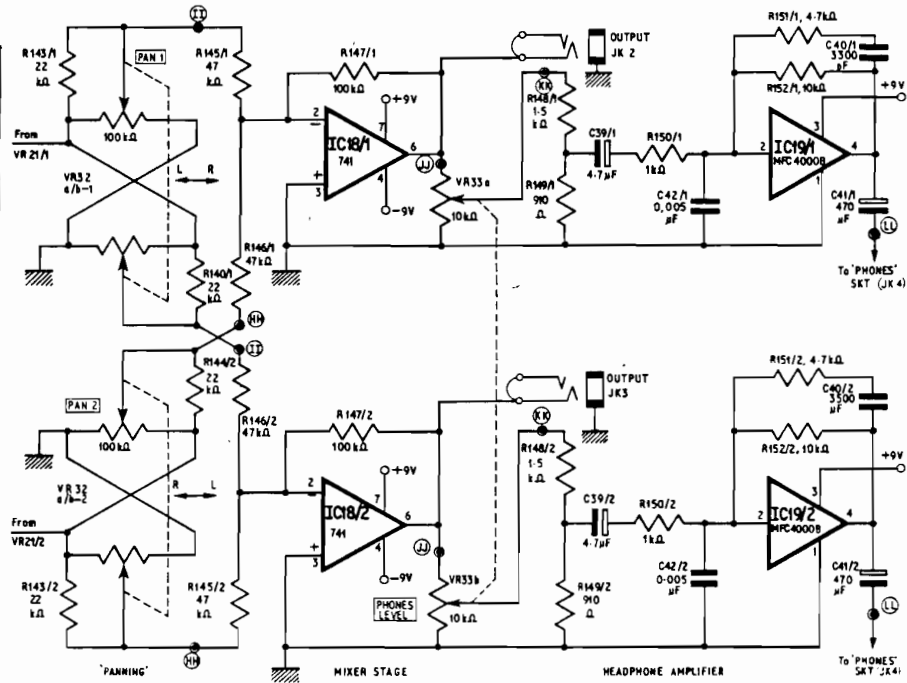

Fig. 18. Circuit of output stages

IC18/1-2 are the mixer stages, each having two inputs. The outputs from the mixer stages drive into VR33a/b which provides level control to both output sockets and to the headphone amplifiers IC19/1 and 2. The headphone amplifiers themselves are based on the MFC4000B, a 250mW power stage by Motorola.

These units are quite suitable for driving direct into a pair of low impedance headphones (around 8 ohms) although it may be that a suitable listening level can only be obtained at the expense of reducing the setting of VR33 to a point where the signal at the output sockets is too small, i.e. substantially less than one volt. If this is the case the gain of the headphone amplifier may be reduced by increasing the value of R150. Doubling the value of this resistor will effectively halve the gain and thereby allow an increase in the input signal for comfortable listening.

CONTROL ENVELOPE INVERTER

In the original Minisonic the control envelope inverter provided a means whereby a negative going envelope could be used to modulate other voltage controlled circuits in the instrument. Although the positive going envelope was also available, it was uncontrolled and thus limited in its usefulness. In the Mark II instrument the same basic circuit is used with the addition of a level control at the input.

The circuit of the control envelope inverter is shown in Fig. 19. IC20 is a unity gain inverter driven by a positive going signal derived from Envelope Shaper 1. The positive envelope together with the negative envelope derived from the output of IC20 are both routed into the modulation control switching via VR34 and VR35 respectively.

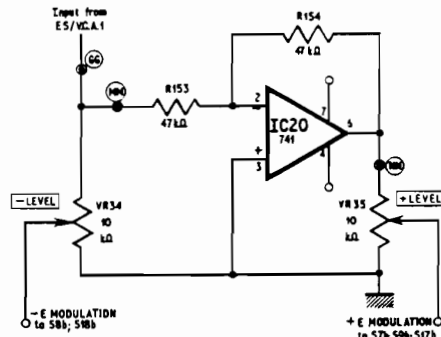

Fig. 19. Circuit of the control envelope inverter and modulation signal routing

COMPONENTS . . .

CONTROL ENVELOPE INVERTER

Resistors	
R153-154	47k Ω (2 off)
All \pm 5% $\frac{1}{4}$ W carbon	
Potentiometers	
VR34-35	10k Ω lin. (2 off)
Integrated Circuits	
IC20	741

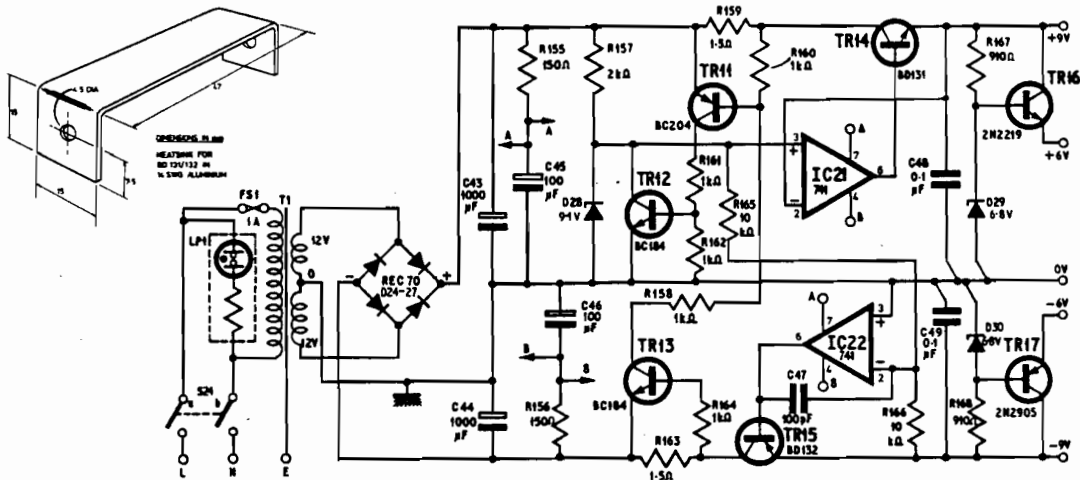

Fig. 20. P.s.u. and voltage reference supply

It should be noted that there is an apparent paradox in the naming of the control envelopes. The $-E$ modulation is, in fact, the positive going envelope and vice versa. This nomenclature was adopted because it was felt more important to name the control envelopes in terms of their function rather than on their polarity.

For example, the $+E$ modulation causes an increase in frequency of the v.c.o.s and expands the passband of the v.c.f. while the $-E$ modulation has the opposite effect.

COMPONENTS . . .

POWER SUPPLY UNIT

($\pm 9V$ p.s.u. and $\pm 6V$ reference unit)

Resistors

R155-156	150 Ω (2 off)	R163	1.5 Ω
R157	2k Ω	R164	1k Ω
R158	1k Ω	R165-166	10k Ω (2 off)
R159	1.5 Ω	R167-168	910 Ω (2 off)
R160-162	1k Ω (3 off)		
All $\pm 5\%$ $\frac{1}{4}W$ carbon			

Capacitors

C43-44	1,000 μF elect. 16V (2 off)
C45-46	100 μF elect. 25V (2 off)
C47	100pF polystyrene
C48-49	0.1 μF ceramic (2 off)

Transformer

T1-0-12V/0-12V/6VA mains transformer

Semiconductors

IC21-22	741 (2 off)	TR14	BD131*
TR11	BC204.or	TR15	BD132*
	BC213/BC214	TR16	2N2219
TR12-13	BC184	TR17	2N2905
D24-27	REC70 bridge rectifier (RS)		
D28	9.1V 400mW Zener		
D29-30	6.8V 400mW Zener		

* mount in heatsink

Switch

S24 2 pole c/o main push button (Jean Renaud)

P.S.U. AND REFERENCE VOLTAGES

Both the p.s.u. and the reference voltage section of the original Minisonic exhibit a number of amendments. In the case of the negative rail regulator the 741 operational amplifier takes its d.c. feedback from the emitter of TR15 rather than from its own output. Additionally a 100pF capacitor provides an a.c. feedback loop around IC22 in order to limit the tendency towards oscillation on the negative rail. The current sensing resistors R159 and R163 have been reduced from 6R2 to 1R5 in order to extend the limiting range of the circuit.

In the voltage reference section emitter follower transistors are included in order that the current demands on the 6V rails may be more adequately met. Paradoxically this latter modification reduces the quiescent current drain by more than 30 per cent thereby making it more than ever feasible to drive the instrument from batteries.

Although, as originally, a dual secondary 12V transformer is specified, it is quite possible to utilise a dual secondary 9V type such as the Douglas MT235 CS. This is due to the fact that the mean current drain of the complete instrument is around 40mA and thus the loading on the transformer is such as to leave a margin of two to three volts across the series-pass transistors TR14 and TR15.

CIRCUIT

The complete circuit of the power supply unit and voltage reference supply is shown in Fig. 20. A dual secondary transformer and conventional arrangement of bridge rectifier and smoothing are employed. It would, of course, be possible to employ a 24V centre-tapped transformer in this arrangement but in no circumstances should these voltages be exceeded otherwise there is a danger that the operational amplifiers may become damaged. Transformers offering a total secondary voltage lying in the range 18V to 24V may be employed providing that their specified power rating is at least 6VA.

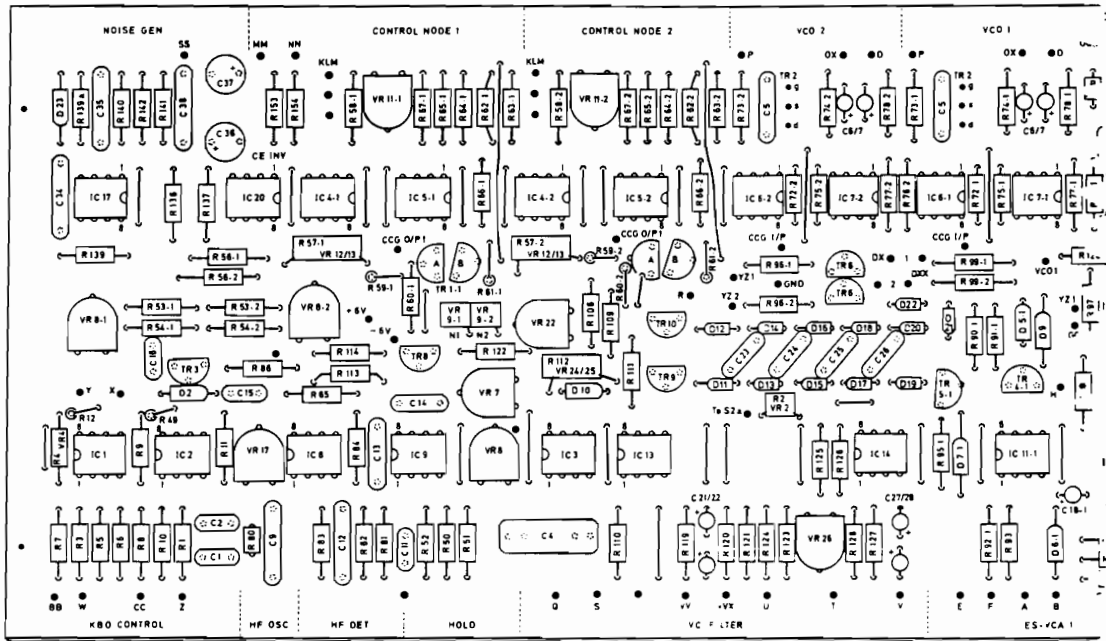
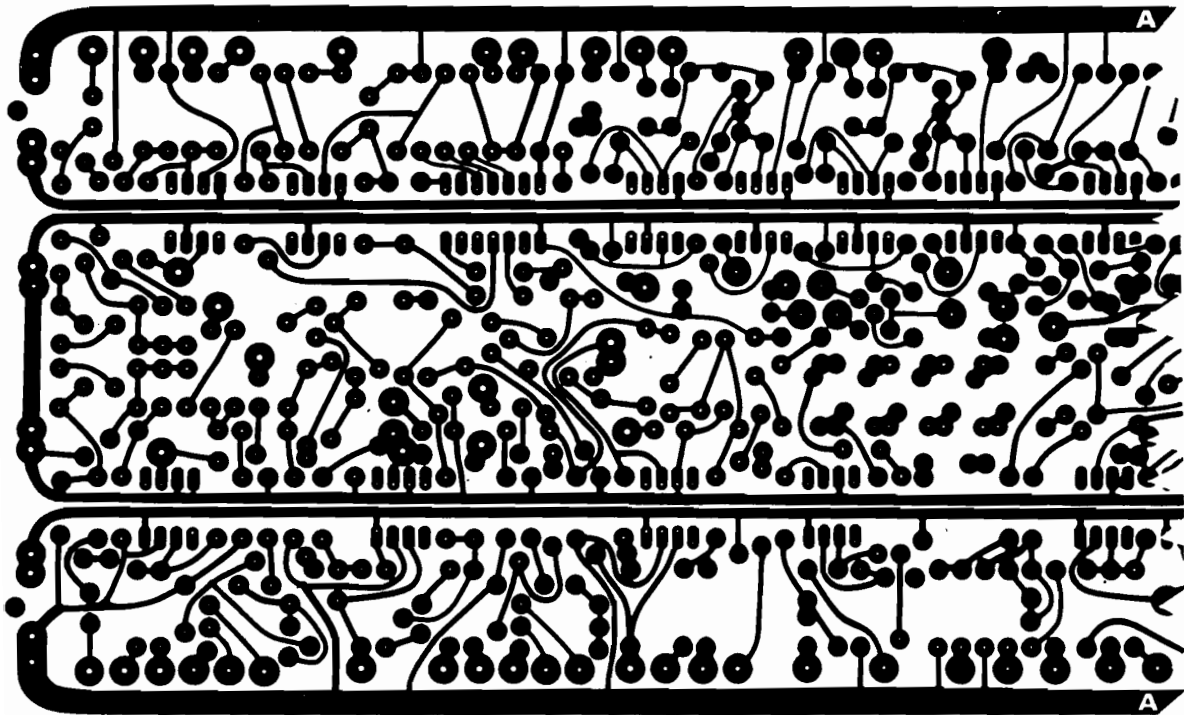

Fig. 21. Main circuit p.c.b. master (full size). Note that each section should be overlapped at "A". Also, all pad areas should be drilled for components



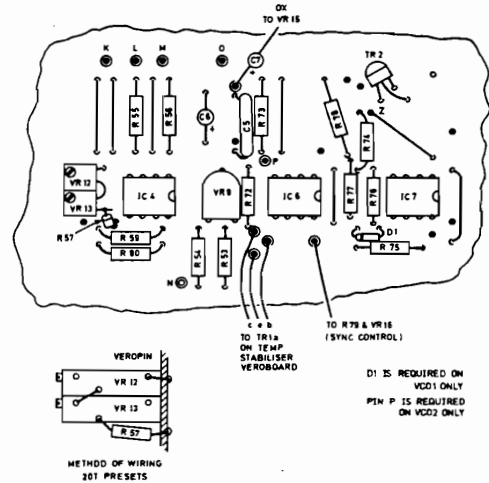
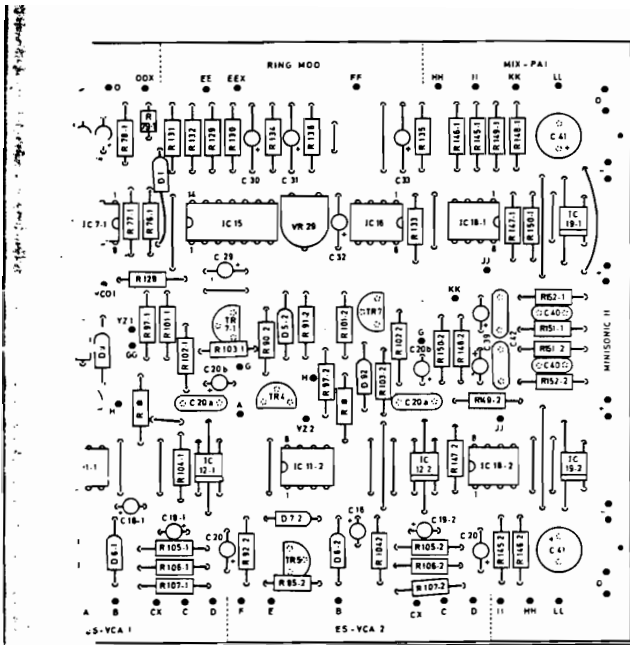

Fig. 23. Modifications required to the original Minisonic p.c.b.

Fig. 22. Component layout of main circuit p.c.b.

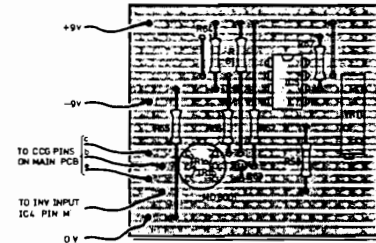
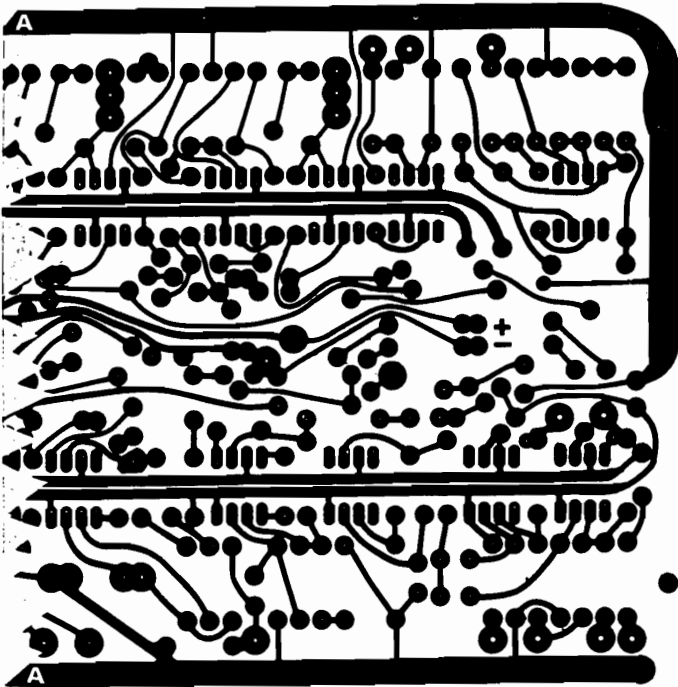

Fig. 24. Component layout for temperature stabilisation circuits for modified Minisonic

COMPONENTS . . .

KEYBOARD

- 1 Pair of end cheeks
 - 3 octave C-C keyboard
 - 37 contact assemblies type GJ s.p.c.o.
- (All items available from Kimber Allen)

MISCELLANEOUS

- 3 Panels (see figures), 23-2 pole changeover push button switches (Jean Renaud), 24 chrome push buttons, 21 aluminium knobs 18 mm dia., 3 aluminium knobs 22 mm dia., single switch mount, 10 way switch mount, 6 way switch mount, 10 turn analogue dials (2 off), 1-1/4 in. stereo socket (JK4), 2-1/4 in. mono sockets (JK2/JK3), 1-1/4 in. mono breakjack (JK1), miniature mains plug and socket (2 off), 4 metres of 0.4 sq. mm mains cable, 4BA x 6 mm screws, nuts and washers (16 off), 4BA x 12 mm self tapping screws (4 off), 4BA x 12.7 mm screws, nuts and washers (4 off), 6BA x 6mm countersunk screws, nuts and washers (4 off), rubber feet (4 off)

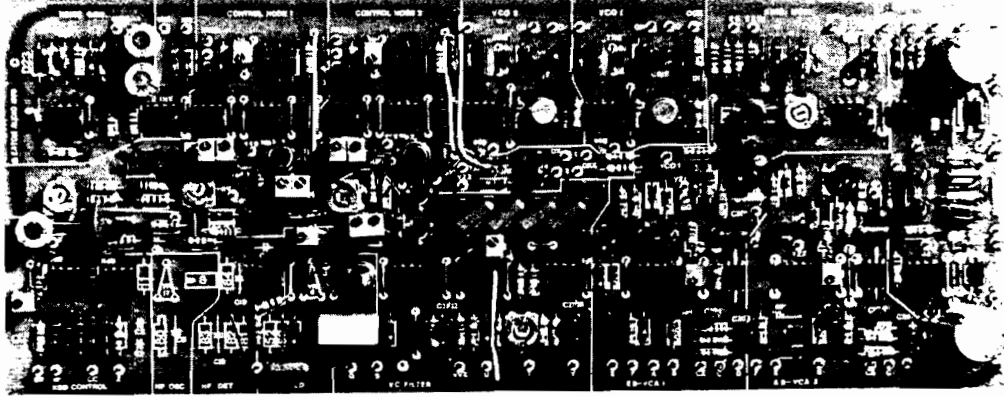

Assembled main p.c.b. except for h.f. oscillator and detector areas

The reference voltage for the power supply is derived from a Zener diode which provides the input signal to IC21 and IC22. IC21 operates as a follower and drives the positive series pass transistor TR14 with overall feedback being taken from the emitter of this device.

IC22 is connected as an inverter and drives the negative series pass transistor TR15 with a similar feedback arrangement as for the other rail. In this latter case, however, it is necessary to provide some a.c. feedback around IC22 in order to restrict the tendency towards oscillation on the negative rail. Current limiting is provided by means of the arrangement comprising TR11, TR12 and TR13. The operation of the current limiting circuit is as follows: In the case of the positive rail, normal current demands result in a minimal potential difference across R159 and thus the base of TR11 is almost at the same potential as its emitter. TR11 is therefore not conducting. As the current drain increases, however, the p.d. across R159 also increases to the point at which TR11 starts to conduct. In these circumstances TR12 is progressively turned on and reduces the reference voltage by shorting out the diode across it.

Similarly, in the negative rail TR13 provides current limit control. In this case, however, when TR13 begins to conduct it has to turn on TR11 before affecting the reference voltage in the way previously described. With the values given the circuit will pass currents of up to 200mA before limiting occurs.

REGULATION

Within the current limits quoted, short term regulation is carried out by means of the operational amplifiers IC21 and IC22. A sudden increase in the current demand on the positive rail, for example, will tend to cause the voltage to fall. This is reflected at IC21 in terms of reduced feedback and thus the output will drive positive in order to restore the situation. The reverse situation will occur when there is a reduction in the current demand.

The 6V reference rails are derived from R167, D25 and TR16 for the positive 6V rail and from R168, D26 and TR17 for the negative rail. The actual value of the reference voltages will depend on the absolute value of the Zener voltages and it is not necessary that they are maintained at exactly 6 volts. The main thing is that these rails should be as stable as possible and that the transistors TR16 and TR17 are able to meet exceptional current demands such as during periods when the v.c.f. is being driven hard.

If it is found that, in such latter circumstances, the reference rails show a drop in voltage—particularly the negative rail—then it will be necessary to make a token reduction in the appropriate Zener series resistor in order to provide more drive to the transistor.

PRINTED CIRCUIT BOARDS

It is appreciated that there will be a number of constructors who, having built the original Minisonic, will want to consider the possibility of converting their instruments into the Mark II version. Such an operation is quite feasible, indeed there are quite a number of Minisonic IIs in circulation in which the majority of the modified circuits are incorporated into the original circuit board.

Details of p.c.b. modifications are therefore included here but are limited to the major circuit amendments such as the oscillators. To contain the hold isolator and modifications for the original p.s.u. p.c.b. it is probably simpler to make up the board as in Figs. 25/6. Most of the other modifications require only the addition or deletion of the odd component and it is felt that most constructors having got this far will be perfectly able to carry out the necessary work without special instructions.

Fig. 21 shows the copper side of the main circuit board devised for the Mark II Minisonic, while the component layout for the same board is given in Fig. 22.

Fig. 23 gives the modifications required to the original Minisonic p.c.b. in order that it can carry the re-designed v.c.o.s. The layout of this particular board

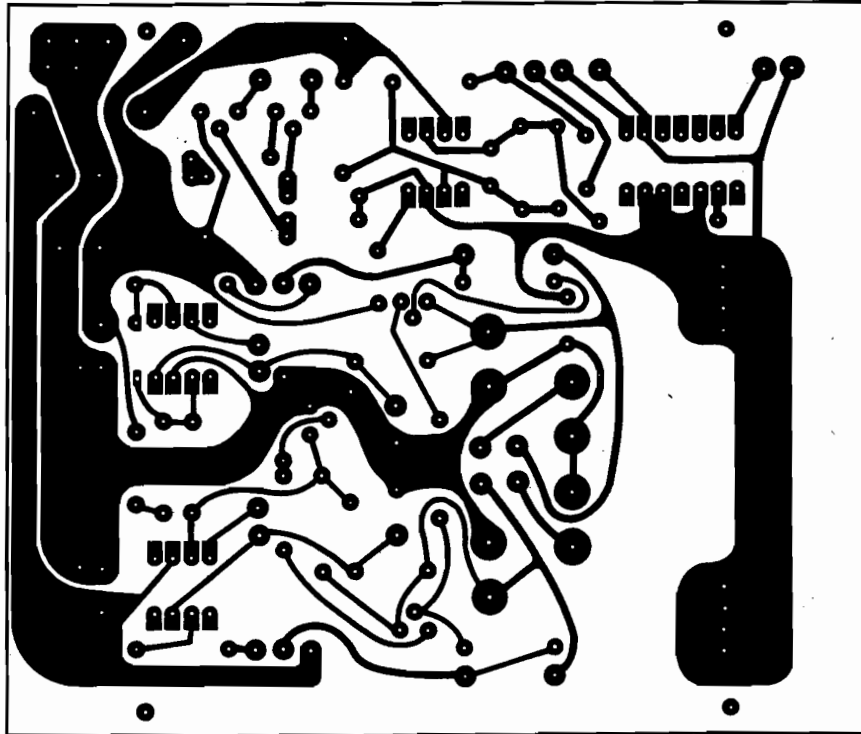

Fig. 25. Mark II p.s.u. p.c.b. incorporating reference supply and hold isolator

is not sufficiently compact to enable inclusion of the independent temperature stabilisation circuits for the new oscillators, so these are shown on a Veroboard layout in Fig. 24.

This small additional Veroboard can be mounted adjacent to the main p.c.b. in the finished instrument. In the prototype Minisonic II the additional board was divided and mounted directly over the comparator stage of the v.c.o.s on short pillars.

The revised power supply p.c.b. for the Minisonic II is shown in Fig. 25 for the copper side and in Fig. 26 for the component layout. This particular circuit board carries the power supply unit, the reference voltage supply and the additional circuit known as the hold isolator.

INSTRUMENT HOUSING

A general idea of the construction of the Minisonic housing is given by the accompanying photographs.

The recommended 3-octave keyboard for the Minisonic is supplied by Kimber-Allen Ltd. The exceptionally rigid aluminium extrusion comprising the baseframe of the keyboard acts as a bridge between the two end cheeks of the instrument which are detailed in Fig. 27. Further rigidity is imparted to the structure by means of the base panel which is permanently screwed to the aluminium brackets fixed to the end cheeks. The front panel of the instrument is screwed to the sloping aluminium brackets while the rear panel is hinged to the front panel and secured to the base by means of four self-tapping screws.

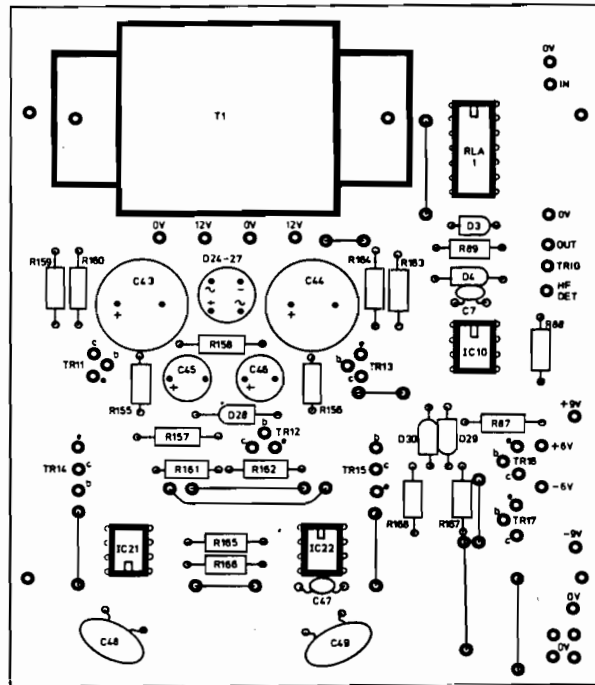
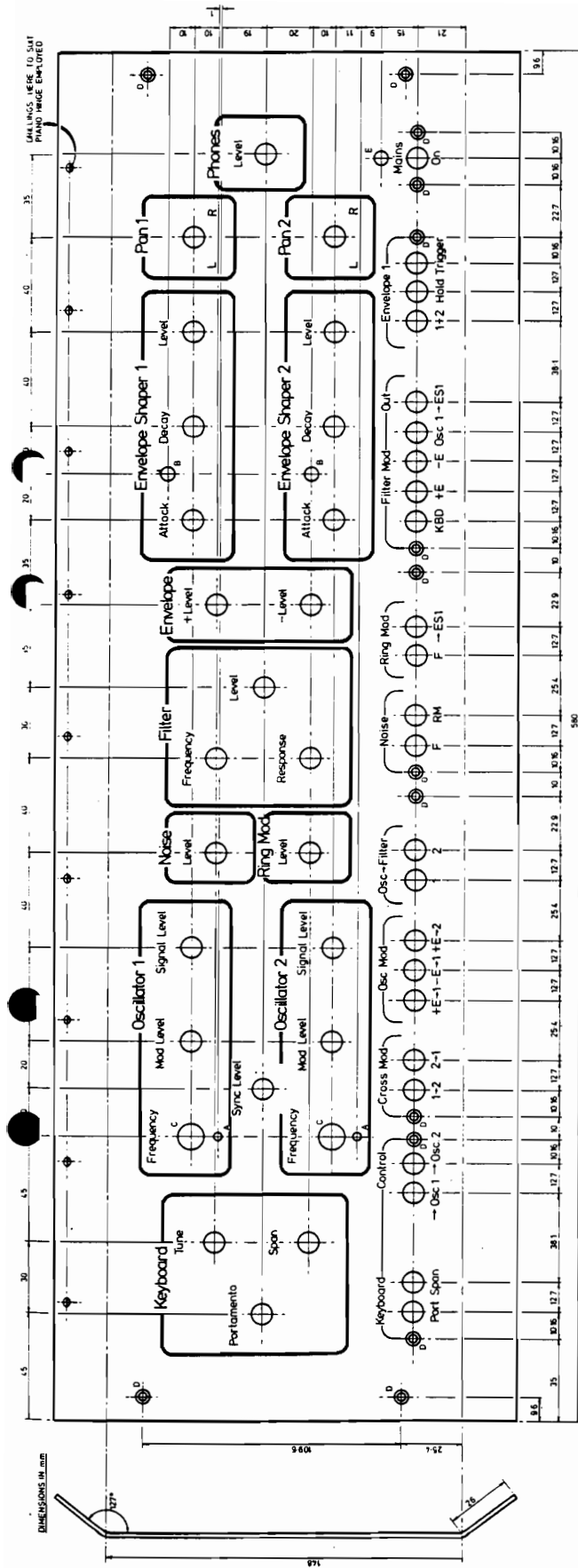

Fig. 26. P.s.u. p.c.b. component layout



KEYBOARD PREPARATION

After making up the end cheeks as detailed in Fig. 27 the first stage in the assembly of the housing should be the preparation of the keyboard.

The keyboard baseframe is screwed to the 89mm long thickened portion of the dummy keys. To ensure a flush fit it will be necessary to remove that part of the felting which extends to the end of the upper surface of the keyboard baseframe. It will also be necessary to file away approx. $\frac{3}{32}$ in (2.5mm) from the lower edge corners of the baseframe extrusion so that it clears the upper edge of the aluminium angles.

When this has been done the keyboard can be offered to each end cheek in turn and aligned with the dummy keys in preparation for drilling the securing screw holes. Two 3mm holes should be drilled approximately along the centre line of the dummy key and about 65mm apart. The holes should go through the baseframe and extend to a depth of about 15mm into the dummy key.

When both end cheeks have been similarly drilled the holes in the keyboard baseframe should be enlarged to accommodate No. $6 \times \frac{1}{4}$ " woodscrews which are used to secure the baseframe to the end cheeks.

During assembly of the keyboard to the end cheeks ensure that the baseframe closely abuts the inner face of the cheeks. If this is not done there will be unsightly gaps when the other panels are applied.

CONTACT ASSEMBLY

With the keyboard mounted between the end cheeks the assembly of the keyboard contacts can be started. Kimber-Allen single pole change-over contacts of the G.J. type are recommended and these should be mounted on a strip of 2mm x 50mm hardboard. The hardboard should be cut to extend approximately 12mm either side of the keyswitch actuators and initially placed loosely in position parallel to and about 15mm behind the line of the actuators. The contact assemblies are now placed on the hardboard strip such that their moving wire is centrally over the actuator and glued into position using Araldite Rapid.

When all assemblies have been positioned and set the whole hardboard strip may now be glued to the keyboard baseframe such that the moving wires are central to and extend beyond the actuators by approximately 5mm. The keyboard divider resistors are now fitted to the contact assemblies generally as shown in Fig. 28 with the mating wires connected as a bus-bar. No further wiring of the keyboard is required at this stage.

Fig. 30. Front panel details including control legends

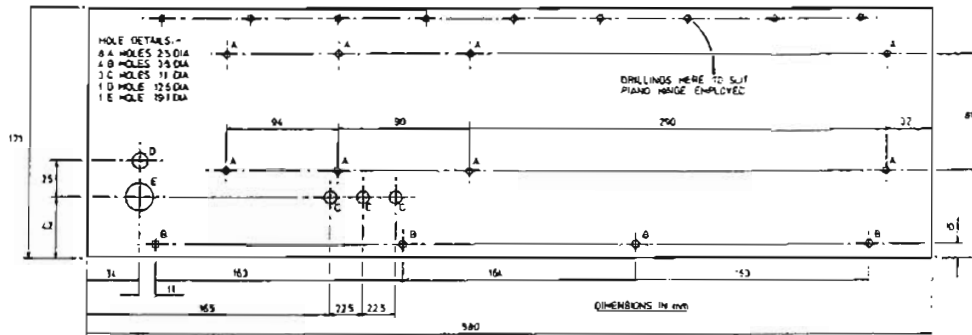

Fig. 31. Rear panel detail

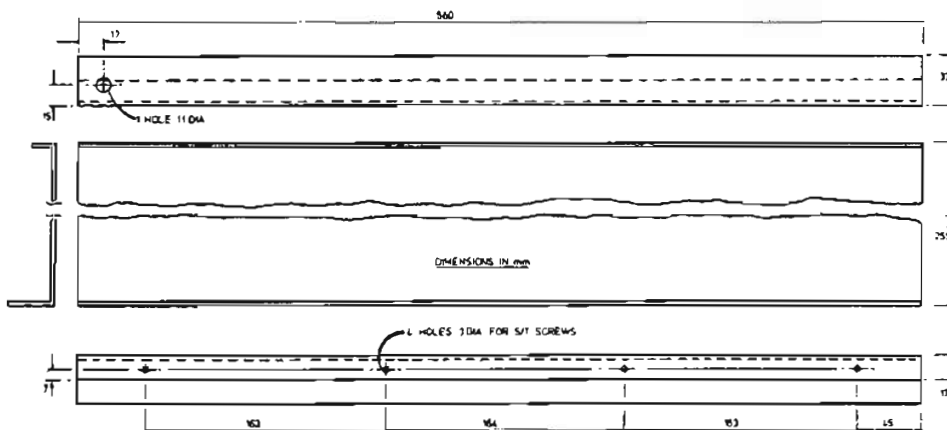

Fig. 32. Base panel detail

PANEL WORK

Bending and assembly details for all panels are shown in Fig. 29 while drilling and cutting details for front, rear and base panels are given in Figs. 30, 31 and 32 respectively. Having prepared and finished the panels as specified the assembly of components into the front and rear panels can be started.

In the case of the front panel all potentiometers and switches should be mounted in position and the switches wired as shown in the photograph. At the same time all those potentiometers having a connection to the 0V rail can be linked with a stout copper wire. The only one of these which is not absolutely straightforward is the pan-pot, and a wiring diagram for this device is shown in Fig. 33.

When component assembly and initial wiring on the panels has been completed the front and rear panels may be joined together by means of the piano hinge and the assembled—and tested—circuit boards mounted to the rear panel on 12mm standoff spacers. The main wiring may now be carried out with the panels opened out and laid flat.

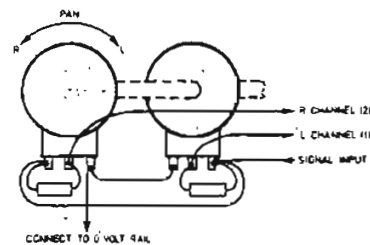

Fig. 33. Pan pot wiring

WIRING HARNESS

It is strongly recommended that constructors take the trouble to make up a properly formed wiring harness for the job of interconnecting all the various circuits and controls in the instrument. The extra effort is adequately rewarded in terms of neatness of the finished layout and in the ease of servicing when this requires to be carried out.

For ease of making up a wiring harness diagram should be drawn in full scale on to a sheet of squared paper. With the drawing then pinned out on a piece of

Prototype Minisonic shown inverted and opened up. Note the wiring harness layout.

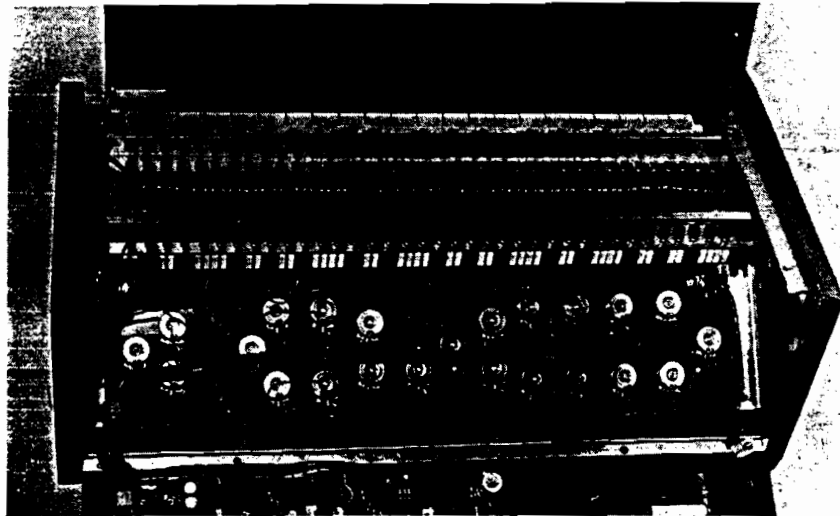

board two parallel rows of ordinary nails should be laid along each main route of the wire runs. The channels so formed will retain the wire runs as the harness is assembled.

At each point where a wire has to exit the harness place another nail in line with the point to which the wire is to be routed and, finally, yet another nail at the termination point of each wire run. Additional nails may be required at various points to retain groups of wires exiting the main harness at different places.

When all wire leads have been laid down the next step is to lace them up into a tight harness. The half knots on each terminal nail should now be untied and the wires trimmed to length, stripped ready for soldering and, in the case of the screened wires, pre-tinned. On the screened wires the insulation and lap screening should be cleared back about 15mm from the tip of the signal wire.

LAYING THE HARNESS

The harness may now be lifted from its channels and laid on to the opened out panels carrying the circuit boards and controls ready for soldering up.

When the main harness has been soldered into position the panels are lifted on to the instrument and the front panel secured to its aluminium support brackets. The connections to the keyboard divider chain and busbar are made at this stage. Finally, with the instrument on its side—resting on one end cheek—the leads to the headphone socket are connected and the base panel secured into position.

Having connected the power supply and mains leads the instrument is now ready for final lining up and testing.

FINAL CHECK OUT

If the testing and setting up procedures outlined in the circuit description have been carefully followed then the final check out will be a straightforward

verification of circuit performance. Where batteries have been used for the initial testing rather more care will be required since the operating voltages will undoubtedly be slightly different and reference voltages such as that set by VR9 in the v.c.o. control nodes will perhaps require some adjustment.

The principal points requiring attention are as follows:

1. Check that the voltage appearing across VR10 in the v.c.o. control nodes is precisely 5 volts.
2. Depress S22 (you are switching the ES/VCA's "on").
3. Check that the "law" on each oscillator is 500mV/octave. Note that this is a nominal figure only and that, providing that the law of the oscillators is precisely the same, some variation from the nominal value can be tolerated.

The law verification should be carried out using the manual frequency controls (VR10). If the law does vary from the nominal value VR9 should be re-adjusted so that the voltage across VR10 is equal to ten-times the law voltage. This will ensure that each full turn of VR10 will shift the oscillator frequency by one octave.

4. Check that, for a given voltage on the wiper of VR10 in both oscillators, the frequencies are within a few Hertz of one another. This check should be made at a number of points over the full swing of VR10.
5. Connect a voltmeter set to 2.5V range across pins "X" and "Y" on the p.c.b. positive lead to pin "Y". Set VR5, the "Tune" control, to approximately mid-position and with S2 in the out, or open, position adjust VR2, the fixed "Span" preset so that the voltmeter reads precisely three-times the law voltage. If the law is set to 500mV/octave then the meter should read 1.5V.

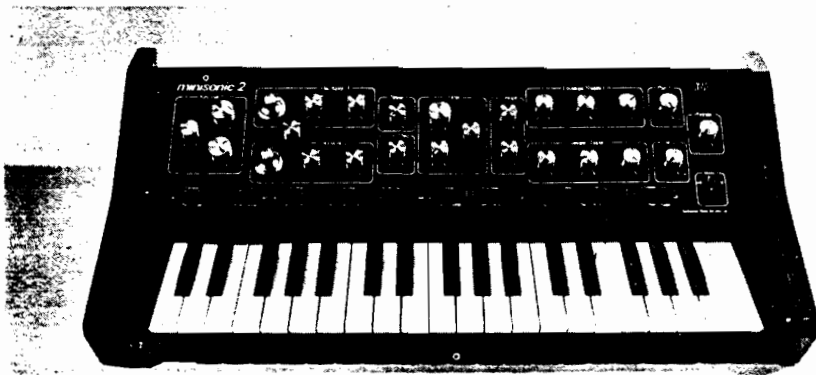

The completed Minisonic 2 showing control panel and keyboard

With one oscillator only being monitored verify that the keyboard plays in an equal temperament scale. Adjust VR2 as necessary to achieve an equal temperament scale.

- Set both oscillators to exactly the same frequency by means of the manual frequency controls. Press any one key on the keyboard and note whether both oscillators remain in unison. Repeat at various points over the span of the keyboard.

If any marked departure from unison is noted this will more than likely be due to some variation in the values of R68/1 and 2. Either one of these resistors can therefore be removed from its switch and replaced with a 50K preset which should be adjusted until unison is achieved.

- With channel 1 panning control hard anti-clockwise and channel 2 panning control hard clockwise release the "Hold" switch (S22). Set the v.c.a. level controls to maximum and headphone level control to maximum. Check that there is no signal breakthrough in either channel with the oscillators running at a convenient mid-range frequency. If breakthrough is present in either channel adjust the appropriate VR20 to minimise the effect.

SIGNAL AND CONTROL ROUTINGS

This completes the most important aspects of final setting-up. The functions of the remaining circuits can be checked out with reference to the signal routing diagram (Fig. 10) and the details given in their respective descriptions.

Similarly the modulation routings should be individually checked with reference to the appropriate sections and figures.

Having built the Minisonic II it now remains for the constructor to gain an understanding of the instrument's various controls and of the combinations of signal and control routings which give rise to particular forms of sound.

MINISONIC 2 POSTSCRIPT

In Fig. 1 R1 and R7 are changed to $10k\Omega$ and $8.2k\Omega$ respectively. VR5 should be a $10k\Omega$ linear carbon potentiometer. L1 may be omitted, particularly when dual contact keyswitches are employed.

Confusion has arisen as a result of Fig. 1 showing two connections from the single pole keyswitches. These are marked "To H.F. Detector (C11)" and "To H.F. Detector (Stylus)". On the p.c.b. these are, in fact, the same point. The purpose of showing the two connections was an aid to those constructors who were converting the original Minisonic to the Mark 2 version. It is suggested that the upper marking (H.F. Detector—C11) be substituted for the lower and the upper arrow deleted.

Some constructors have experienced difficulty in setting up the temperature compensation the main problem being related to the biasing of TR1/b (Fig. 3). It is suggested that R63 is soldered into the p.c.b. on long leads, with the circuit assembled, the output of IC5 is measured. This should be in the range $0.5V-0.75V$. If the output is substantially less than $0.5V$, R63 should be increased in the value—by easy stages—until the required output is achieved.

Testing the control node should be carried out in accordance with the details given. Note however that the ideal situation is when adjustment of VR11 will change the control characteristic, during the finger test, from a negative one (oscillating frequency increasing) to a positive (oscillator frequency decreasing).

In Fig. 8 R98, R100 and D8 can be omitted since i.e.d. indication of envelope state is adequate.

In Fig. 11 D10 should be shown spanning all three resistors in the feedback line.

Note that the MFC6040 used in the v.c.a. is now replaced by the MCP3340 a device having similar characteristics but in an eight pin d.i.l. package.

The simplest way to accommodate them is on a small piece of Veroboard supported above the main p.c.b. by stiff wire links connected to the appropriate drilling for the MFC6040. ★